

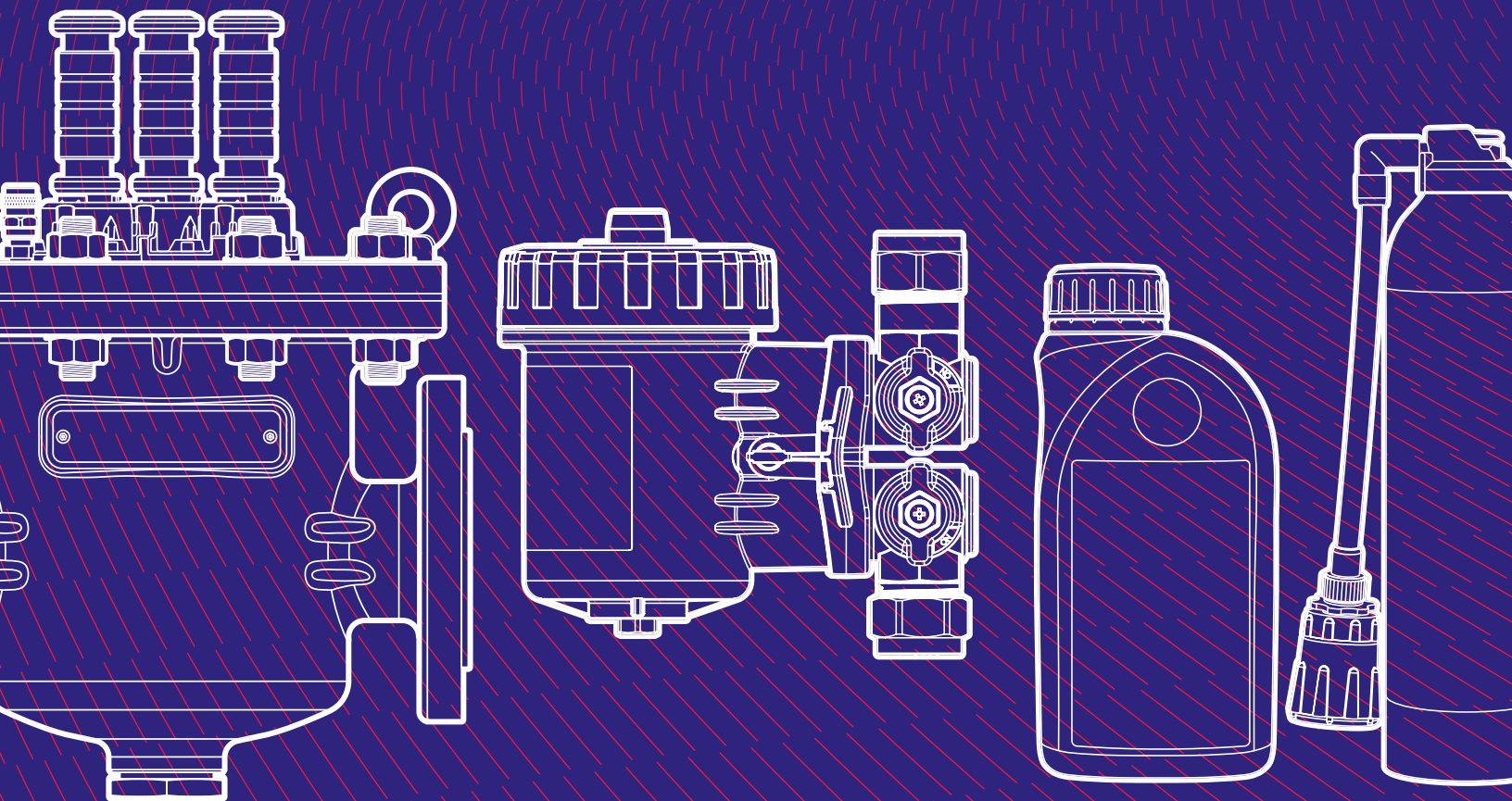

ADEY[™]

Product Catalog





Whether it's market leading magnetic dirt filters or award winning water treatment products, we design and manufacture effective solutions for protecting hydronic systems throughout North America.

Contents

ADEY® Best Practice	4
Residential filters	
<i>MagnaClean Micro2®</i>	8
<i>MagnaClean Professional2®</i>	10
<i>MagnaClean Professional2XP®</i>	12
<i>MagnaClean Professional2XP® ChemPack</i>	14
<i>MagnaCleanse®</i>	16
Light commercial	
<i>MagnaClean DualXP®</i>	18
Commercial filters	
<i>MagnaClean Commercial®</i>	22
<i>MagnaClean DRX®</i>	29
<i>MagnaClean CMX®</i>	34
Water treatment	
<i>MC3+® Hydronic System CLEANER</i>	40
<i>MC5® RAPIDFLUSH System Cleaner</i>	41
<i>MC40+® Boiler Descaler</i>	42
<i>MC1+® Hydronic System PROTECTOR</i>	43
Water testing	
ADEYs Water Testing	45
Maintain	46
Resources	47

ADEY[®] Best Practice

ADEY[®], the industry leaders in hydronic heating and cooling maintenance and water treatment, has developed a range of products to help you deliver effective system protection.

The *ADEY Best Practice* approach promotes the process of test, clean, protect, maintain to prolong system longevity and efficiency.

ADEY has a complete range of products that support the contractor, the engineer, and the end-user throughout the treatment process.

Our products are always designed with a focus on ease of installation and use. With additional support from our team and our Reps, we work with you to provide the best possible protection for hydronic heating and cooling systems.



Test

Test and assess the system water quality.

Test, assess and diagnose the quality of the hydronic system water with our on-site corrosion, pH and *MC1+*[®] inhibitor quick test strips. Plus, test for magnetite with our *MagnaClean RapidTest*[®] stick.

ADEY's Water Testing - page 45

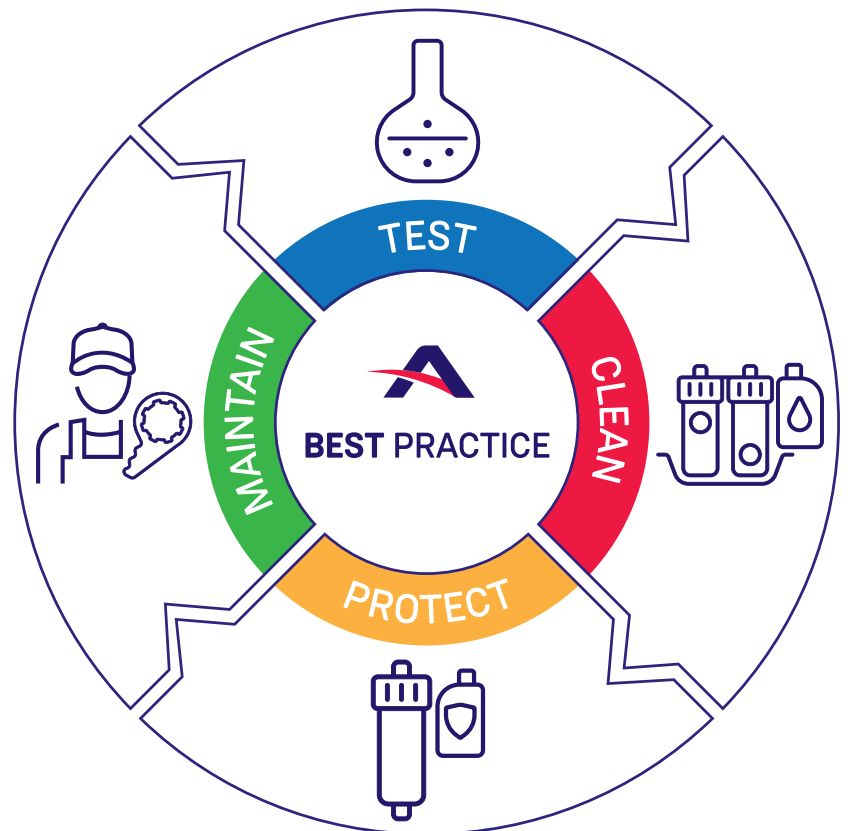



Clean

Clean the system using chemicals and flushing to shift any build up in the system pipes, heat emitters and boiler.

ADEY's *MC3+®* cleaner, *MC40+®* Boiler Descaler and *MC5 RapidFlush™* cleaner lift existing scale and magnetite.

ADEY's *MagnaClean* filters capture the scale and magnetite that has been lifted by the cleaners.

The ADEY *MagnaCleanse®* unit combines flushing and cleaning on a bypass circuit, saving time and water, for a more effective clean.

MagnaCleanse - page 16

***MC3+®* Hydronic System CLEANER** - page 40

***MC5®* RAPIDFLUSH System Cleaner** - page 41

***MC40+®* Boiler Descaler** - page 42



Protect

Protect the system with ADEY *MagnaClean* filters, accessories and chemicals.

Protect the system from on-going scale and corrosion build-up with a combination of ADEY's *MagnaClean* magnetic filters and *MC1+®* protector.

Both of these products are designed to improve hydronic system efficiency and performance.

***MC1+®* Hydronic System PROTECTOR** - page 43

***MagnaClean* Residential filters** - from page 8

***MagnaClean* Commercial filters** - from page 21



Maintain

Provide continuous protection throughout the life of the system with annual servicing and continued chemical protection.

Regular servicing and water testing promotes continual system protection and maintains efficiency.

Water quality levels should be tested annually with ADEY's *MC1+* inhibitor, pH and corrosion quick test strips, and if required, topped up with ADEY's *MC1+* protector

ADEY's *MagnaClean* filter should be serviced regularly.

Maintain - page 46



MagnaClean residential filters

Corrosion is the number one contributor to heating system failures which can be significantly reduced through the installation of magnetic filtration products from *ADEY*.

Today's high-efficiency circulators and boilers are bringing new levels of efficiency and cost savings to homeowners, but they are uniquely vulnerable to a danger lurking in nearly every hydronic heating system - Magnetite, commonly known as black corrosion.

An unavoidable result of oxidation inside untreated systems causes magnetite to form on the surface of pipes and system components where it deposits into the system water as microscopic particles which combine to form a black sludge. Even in small quantities, these particles can potentially cause expensive damage. As sludge accumulates, system efficiency is dramatically reduced, and operating costs increase.

ADEY's range of market leading magnetic filters from the compact *MagnaClean Micro2* to the large powerful capacity of the *MagnaClean DualXP*, specifically target the removal of magnetite within hydronic heating and cooling systems. This product range provides ongoing protection and ensures high operational efficiency.

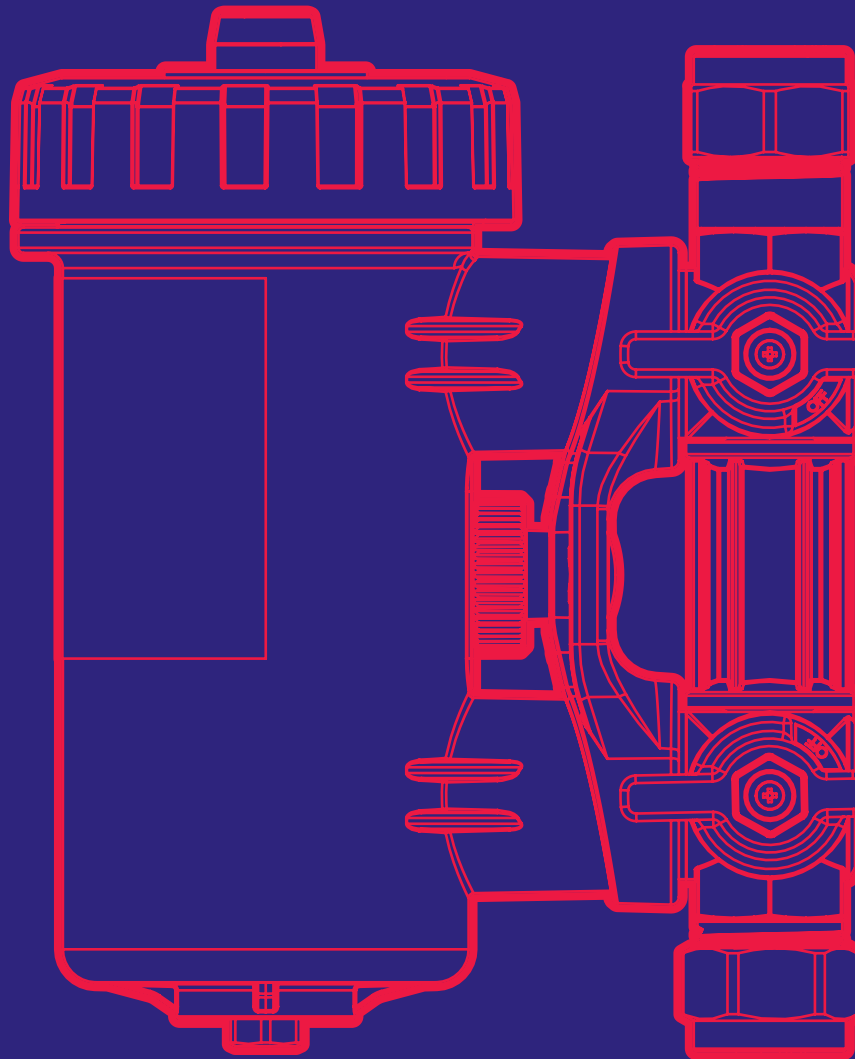

MagnaClean[®] Micro2



Contractor Features and Benefits

Compact in design, the *MagnaClean Micro2* is a double action filter that targets the removal of magnetite in smaller hydronic systems.

MagnaClean Micro2 delivers exceptional protection against the damaging effects of black iron oxide sludge and scale. It is ideal for smaller installations such as, small apartment units, or where access is limited. 3/4" copper compression with 3/4" female NPT adapters

- High performance compact filter = ideal for space restricted
- Smallest servicing height in the industry – 1" clearance above and below
- Magnetic and non-magnetic debris capture zones
- In-line installation can be completed in just minutes
- 360° rotational valves = customizable installation options
- Bi-directional flow = either port can be an inlet for increased flexibility
- Ultra-thin removable sheath / sleeve for easier servicing = rinse over sink to remove magnetite
- Low profile drain valve and built-in air vent designed for easier servicing.
- Twin reverse flow that maximizes capture
- Quick-release trigger and rapid-fit connectors for faster servicing
- Acts as a dosing pot

Where to install?

MagnaClean Micro2 should be installed vertically, in-line, on the return pipe before the heat exchanger / boiler.

A = preferred location

B = if A isn't an option

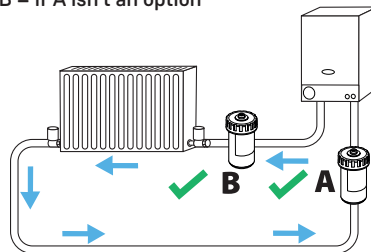

Homeowner benefits

- Extended system life
- Reduced heating bills and maintenance costs
- Immediate ongoing system protection
- Reduced carbon emissions

Product code: FL1-03-02829

ADEY Best Practice essentials:

MC3+[®] Hydronic System CLEANER - page 40

MC5[®] RAPIDFLUSH System Cleaner - page 41

MC40+[®] Boiler Descaler - page 42

MagnaCleanse - page 16

MC1+[®] Hydronic System PROTECTOR - page 43



Protect

Technical specifications

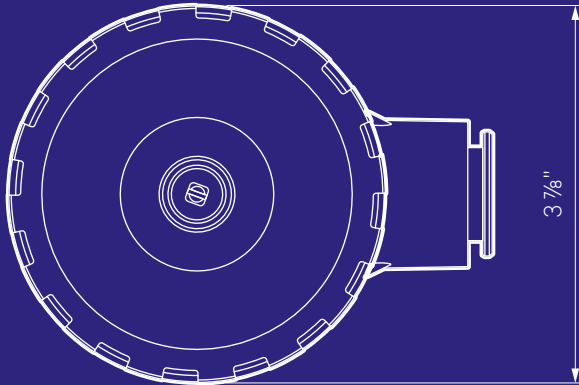

Canister and lid

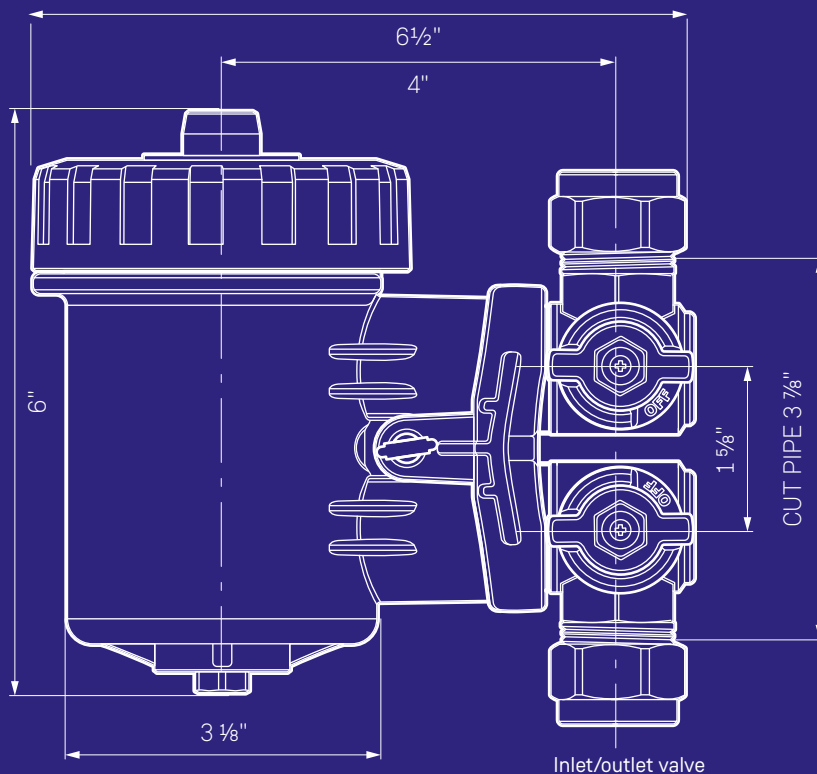

Inlet/outlet valve

Canister and lid

- Material: Glass reinforced nylon
- Fluid capacity: .007 gal / 0.25 litres
- Inlet diameter: 3/4" NPT
- Outlet diameter: 3/4" NPT
- Thread: Pressure thread
- Flow configuration: Bi-directional – either port can be inlet
- Main lid seal: EPDM
- Valve to canister: EPDM

Magnet

- Housing: Stainless steel
- Length: 3 7/8"
- Diameter: 3/4"

Bleed valve

- Body material: Nickel plated brass
- Screw: Nickel plated brass
- Thread interface: M6
- Seals: EPDM

Drain port

- Drain plug material: Nickel plated brass
- Drain plug thread: M8
- Seals: EPDM

Triple seal valves

- Body material: Nickel plated brass
- Seals material: Long life PTFE ball seals
- O ring material: EPDM 70 seals x3

Servicing clearance

- Air vent (top): 2"
- Drain Plug (bottom): 2"

Full installation instructions are supplied with each filter and are also available to download from adey.com/us

Max working pressure	87 PSI
Max working temperature	203°F / 95°C
Flow rate	13 GPM
Weight	4 lbs 8 oz

MagnaClean[®] Professional2



Contractor Features and Benefits

Compact in size but substantial in performance, the *MagnaClean Professional2* features a unique, patented magnetic filtration system that starts to work from the moment it is installed.

The unique design of the *MagnaClean Professional2* maximizes capture of hydronic systems number one enemy - magnetite.

The MagnaClean Professional2 is the ideal solution for smaller residence applications.

- 3/4" copper compression with 1" female NPT adapters
- Magnetic and non-magnetic debris capture zones

- In-line installation can be completed in just minutes
- 360° rotational valves = multiple installation options
- Bi-directional flow = either port can be an inlet for increased flexibility
- Ultra-thin removable sheath/sleeve for easier servicing = rinse over sink to remove magnetite
- Low profile drain valve designed for easier servicing and dosing
- Twin reverse flow that maximizes capture
- Rapid fit connectors for faster servicing
- Acts as a dosing pot

Where to install?

MagnaClean Professional2 should be installed vertically, in-line, on the return pipe before the heat exchanger / boiler.

A = preferred location
B = if A isn't an option.

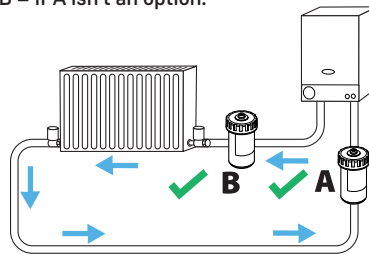

Homeowner benefits

- Extended system life
- Reduced heating bills and maintenance costs
- Immediate ongoing system protection
- Reduced carbon emissions

Product code: FL1-03-02988

ADEY Best Practice essentials:

- MC3+[®]* Hydronic System CLEANER - page 40
- MC5[®]* RAPIDFLUSH System Cleaner - page 41
- MC40+[®]* Boiler Descaler - page 42
- MagnaCleanse* - page 16
- MC1+[®]* Hydronic System PROTECTOR - page 43



Protect

Technical specifications

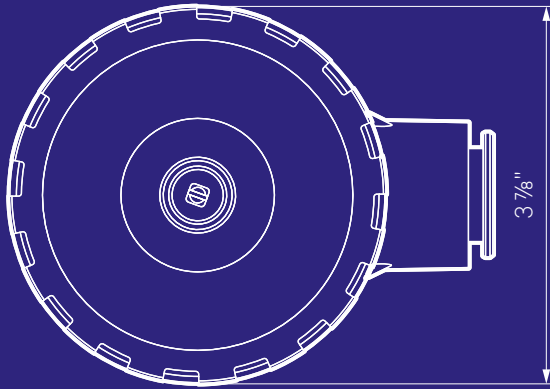

Canister and lid

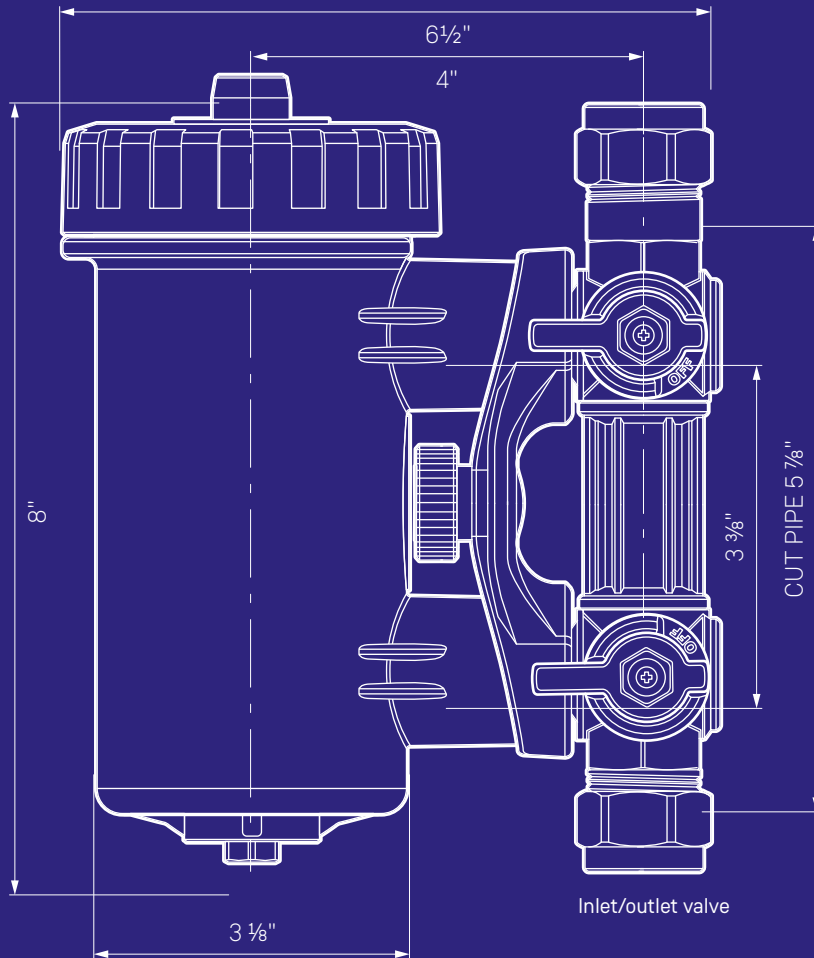

Inlet/outlet valve

Canister and lid

Material: Glass reinforced nylon
 Fluid capacity: 0.15 gal / 0.55 litres
 Inlet diameter: 1" NPT
 Outlet diameter: 1" NPT
 Thread: Pressure thread
 Flow configuration: Bi-directional
 Main lid seal: EPDM
 Valve to canister: EPDM

Magnet

Housing: Stainless steel
 Length: 5 7/8"
 Diameter: 3/4"

Bleed valve

Body material: Nickel plated brass
 Screw: Nickel plated brass
 Thread interface: M6
 Seals: EPDM

Drain port

Drain plug material: Nickel plated brass
 Drain plug thread: M8
 Seals: EPDM

Triple seal valves

Body material: Nickel plated brass
 Seals material: Long life PTFE ball seals
 O ring material: EPDM 70 seals x3

Servicing clearance

Air vent (top): 2"
 Drain Plug (bottom): 2"

Full installation instructions are supplied with each filter and are also available to download from adey.com/us

Max working pressure	87 PSI
Max working temperature	203°F / 95°C
Flow rate	13 GPM
Weight	6 lbs

MagnaClean[®]

Professional2XP



Contractor Features and Benefits

ADEY North America's best-selling filter, the *Professional2XP* has a larger filter capacity to remove greater volumes of magnetite and is the perfect solution for residential hydronic heating systems.

Unlike other magnetic filters, it features specially designed rotational isolation valves, allowing the filter to be serviced without the system being drained, unique ultra-thin sheath/sleeve designed for easier cleaning of magnetite during servicing, and also acts as dosing pot / pot feeder.

- 1" copper compression with 1 1/4" female NPT adapters
- Larger canister and magnet = more magnetic capture
- Magnetic and non-magnetic debris capture zones

- Built-in isolation valves = service without draining system
- 360° rotational valves = multiple installation options
- Bi-directional flow = either port can be an inlet for increased flexibility
- Ultra-thin removable sheath /sleeve for easier servicing = rinse over sink to remove magnetite
- Low profile drain valve designed for easier servicing and dosing
- Improved sheath design for dual scale capture
- Rapid fit connectors for faster servicing
- Acts as a dosing pot

Where to install?

MagnaClean Professional2XP should be installed vertically, in-line, on the return pipe before the heat exchanger / boiler.

A = preferred location
B = if A isn't an option

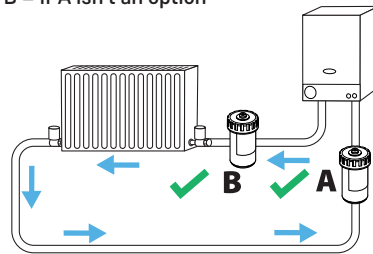

Homeowner benefits

- Extended system life
- Reduced heating bills and maintenance costs
- Immediate ongoing system protection
- Reduced carbon emissions

Product code: FL1-03-02990

ADEY Best Practice essentials:

- MC3+[®] Hydronic System CLEANER - page 40
- MC5[®] RAPIDFLUSH System Cleaner - page 41
- MC40+[®] Boiler Descaler - page 42
- MagnaCleanse - page 16
- MC1+[®] Hydronic System PROTECTOR - page 43



Protect

Technical specifications

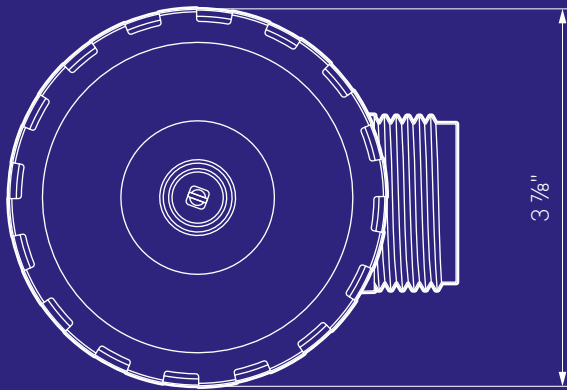

Canister and lid

Material: Glass reinforced nylon
 Fluid capacity: 0.22 gal / 0.84 litres
 Inlet diameter: 1" at valve
 Outlet diameter: 1" at valve
 Thread: Pressure thread
 Flow configuration: Bi-directional
 Main lid seal: EPDM
 Valve to canister: EPDM

Magnet

Housing: Stainless steel
 Length: 8 7/8"
 Diameter: 3/4"

Bleed valve

Body material: Nickel plated brass
 Screw: Nickel plated brass
 Thread interface: M6
 Seals: EPDM

Drain port

Drain plug material: Nickel plated brass
 Drain plug thread: M8
 Seals: EPDM

Triple seal valves

Body material: Nickel plated brass
 Seals material: Long life PTFE ball seals
 O ring material: EPDM 70 seals x3

Servicing clearance

Air vent (top): 2"
 Drain Plug (bottom): 2"

Full installation instructions are supplied with each filter and are also available to download from adey.com/us

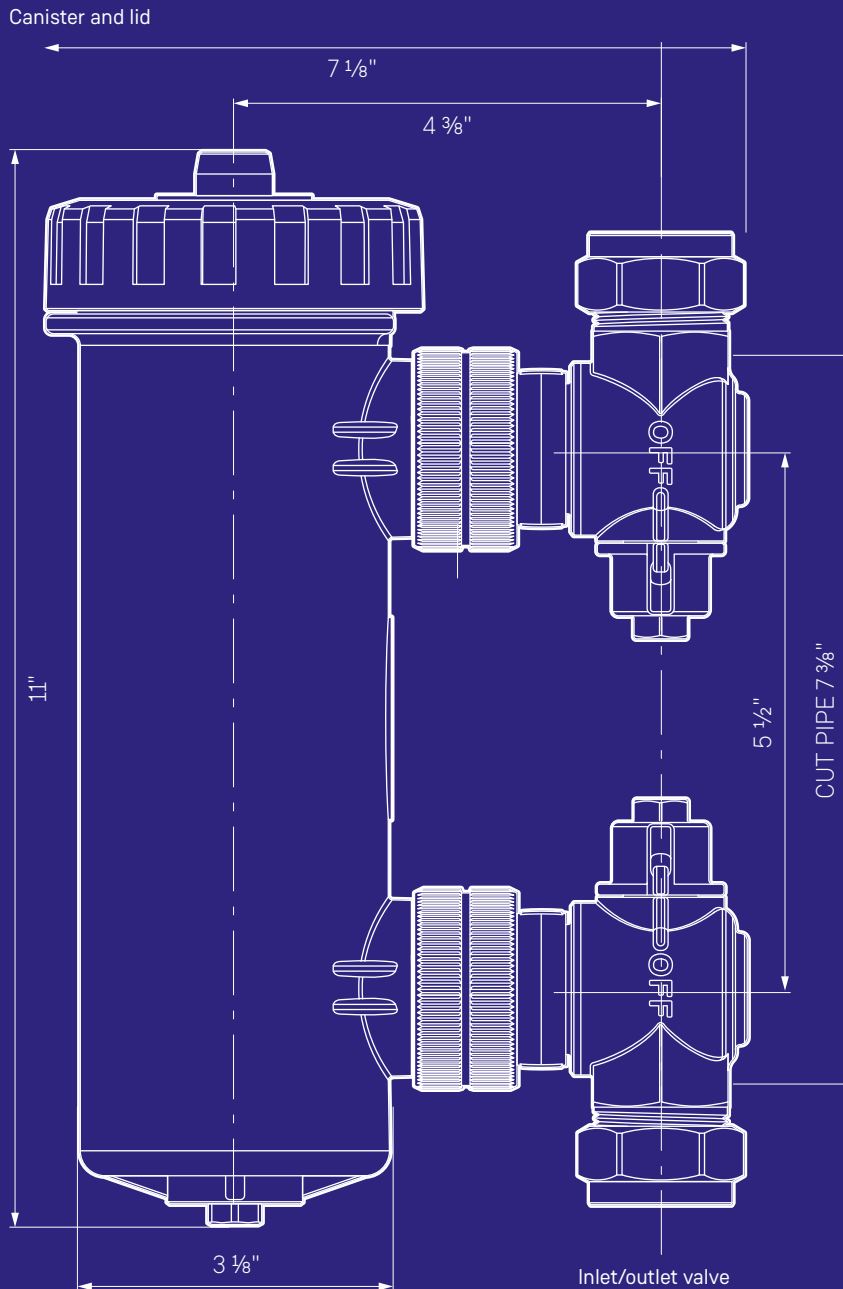

Max working pressure	87 PSI
Max working temperature	203°F / 95°C
Flow rate	21 GPM
Weight	7 lbs 4 oz

MagnaClean[®]

Professional2XP ChemPack



Contractor Features and Benefits

With 1 1/4" NPT connections and a 21 GPM max flow rate, it is no surprise that the MagnaClean Professional2XP is North America's top-seller.

To fully clean and protect a system, the magnetic filter needs the help of cleaner and inhibitor chemicals, which is why we have added a bottle of each in the box, both of which treat 33 gallons of system water.

To make the ChemPack unique, we have also added an automatic air-vent, and a MagnaClean RapidTest stick; our "seeing is believing" tool designed to help you show homeowners the magnetite in their system.

- Test, Clean and Protect all in one box - easy to order and carry
- Unique MagnaClean RapidTest stick designed to help you show homeowners the magnetite in their system
- Automatic air-vent option to aid air removal
- 1" copper compression with 1 1/4" female NPT adapters

- Larger canister and magnet = more magnetic capture
- Magnetic and non-magnetic debris capture zones
- Built-in isolation valves = service without draining system
- 360° rotational valves = multiple installation options
- Bi-directional flow = either port can be an inlet for increased flexibility
- Ultra-thin removable sheath /sleeve for easier servicing = rinse over sink to remove magnetite
- Low profile drain valve designed for easier servicing and dosing
- Improved sheath design for dual scale capture
- Rapid fit connectors for faster servicing
- Canister is a convenient water treatment dosing pot

Where to install?

MagnaClean Professional2XP should be installed vertically, in-line, on the return pipe before the heat exchanger / boiler.

A = preferred location
B = if A isn't an option

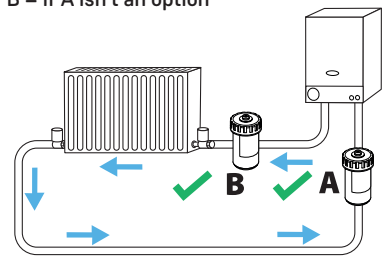

Homeowner benefits

- Reduced heating bills and maintenance costs
- Immediate ongoing system protection
- Extended system life
- Reduced carbon emissions

Product code: FL1-03-06023



2/80	72	FB-38
MAX. PRESS.	MAX. TEMP.	SET AT
125 PSI	225 F	12 lbs

030
VS011
STRAPE

MagnaClean
Professional

MagnaCleanse®

MagnaCleanse offers an easy, tidy and eco-friendly way of cleaning and flushing magnetite from any residential system on a by-pass circuit.

The unit includes transparent hoses, and any adapter kit, allowing the unit to be connected to any existing *MagnaClean* residential filter.

The unit also comes in its own transportable carry case which opens up and allows the dual canisters to sit in the case, acting as a drip tray at the same time to prevent mess during the flushing process.

As the system is in service, the *MC5* cleaner can be dosed into the canisters for a more effective clean. As the cleaner lifts the magnetite, it will circulate around the system until reaching the magnets, where the magnetite will be captured before entering the boiler.

VibraClean™

ADEY's *VibraClean™* radiator agitator is an essential part of the *MagnaCleanse* flushing process. Tests have shown that it is possible to remove more magnetite in 20 seconds than in 30 minutes without *VibraClean*. The precision agitator liberates sludge and hardened deposits without the need to remove the radiator.

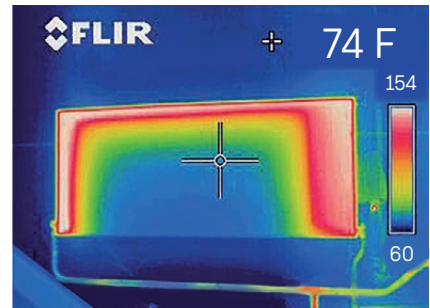

Before system flush.

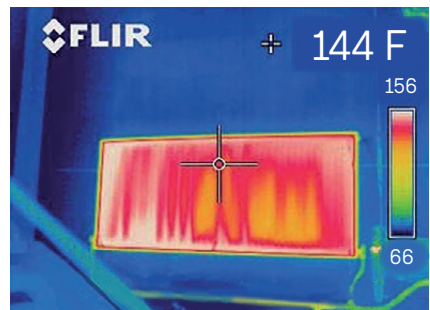

After MagnaCleanse system flush

Contractor benefits

- Working as a by-pass, the system can remain switched on and water remains hot = more effective clean
- Chemical remains concentrated = more magnetite lifted and removed from the system
- Results evident - transparent hoses provide indication as to when system water is clean
- Eco-friendly - water only needs to be drained once at the end
- Transportable and mess-free - comes in its own lightweight carry case which also acts as a drip tray for improved performance and efficiency
- Unique *VibraClean™* agitator tool included, designed to vibrate and dislodge stubborn magnetite from heat emitters

Product code: MACK01-US

Kit contents

The complete *MagnaCleanse* kit gives everything needed to carry out a full system flush:

- 1x *MagnaCleanse* RapidFlush filter
- 1x *VibraClean*
- 1x *MagnaCleanse* hose-to-valve connector
- 1x Hose length
- 6x Hose clamps
- 4x Female cam locks
- 1x Drain valve

No MagnaClean? No problem.

Connect the *MagnaCleanse* up to the boiler with the following additional fittings below:

- 2 x 3" pieces of 3/4" copper
- 2 x 3/4" female adaptors
- Add a 3/4" IPS to the hose and a 3/4" to the boiler drain



Clean



MC5
Rapid Flush
Hydronic System
CLEANER

- Nettoyant pour drainage rapide de systèmes hydroniques
- Limpiador con sistema hidrónico de enjuague rápido



anise™

MagnaClean® DualXP

The *MagnaClean DualXP* has two powerful magnetic capture zones to remove greater volumes of iron oxide sludge and is the ideal solution for large residential and light commercial systems.

MagnaClean DualXP delivers exceptional protection against the damaging effects of black iron oxide sludge and scale. Each port on the *DualXP* has integral flow diverters to both magnetic capture zones, ensuring uniform circulation around the length of both magnets. The *DualXP* comes with 1 1/2" telescopic connections for greater installation flexibility.

Contractor benefits

- Unique 1 1/2" NPT telescopic connectors for easier installation
- Dual magnetic chambers with dual magnets and four non-magnetic debris capture zones
- In-line design and 360° rotational connectors provide versatile installation options, especially for retrofit systems
- Two low profile drain valves for easy servicing and dosing
- Ultra-thin sheath sheaths /sleeves for easier servicing = rinse over sink to remove magnetite
- Bi-directional flow so either port can be used as an inlet or outlet
- Canister is a convenient water treatment dosing pot

Homeowner benefits

- Reduced heating bills and maintenance costs
- Immediate ongoing system protection
- Extended system life
- Reduced carbon emissions

ADEY Best Practice essentials:

MC3+® Hydronic System CLEANER - page 40

MC5® RAPIDFLUSH System Cleaner - page 41

MC40+® Boiler Descaler - page 42

MC1+® Hydronic System PROTECTOR - page 43

Product code: FL1-03-02991



Protect

Technical specifications

Canister and lid

Material: Glass reinforced nylon
 Fluid Capacity: 0.64 gal / 2.43 litres (when telescopic connectors are retracted)
 Inlet diameter: 1" at valve
 Outlet diameter: 1" at valve
 Thread: Pressure thread
 Flow configuration: Bi-directional
 Main lid seal: EPDM
 Valve to canister: EPDM

Bleed valves x2

Body material: Nickel plated brass
 Screw: Nickel plated brass
 Thread interface: M6
 Seals: EPDM

Drain port x2

Drain plug material: Nickel plated brass
 Drain plug thread: M8
 Seals: EPDM

Telescopic connectors x2

Inlet: 1½" Nominal bore
 Outlet: 1½" Nominal bore
 Body material: Nickel plated brass
 Connection: 1½" NPT female
 O ring material: EPDM

Service clearance

Air Vent (top): 2"
 Drain Plug (bottom): 2"

Magnets x2

Housing: Stainless steel
 Length: 8 7/8"
 Diameter: ¾"

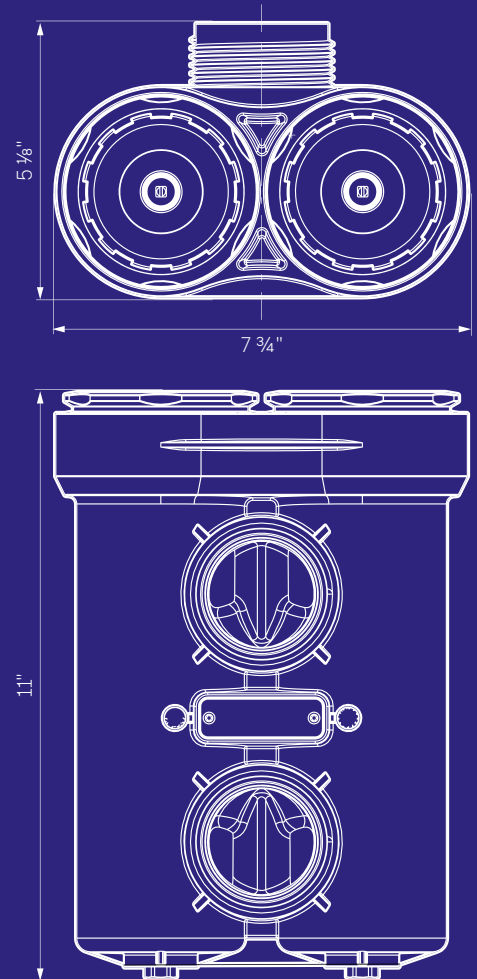
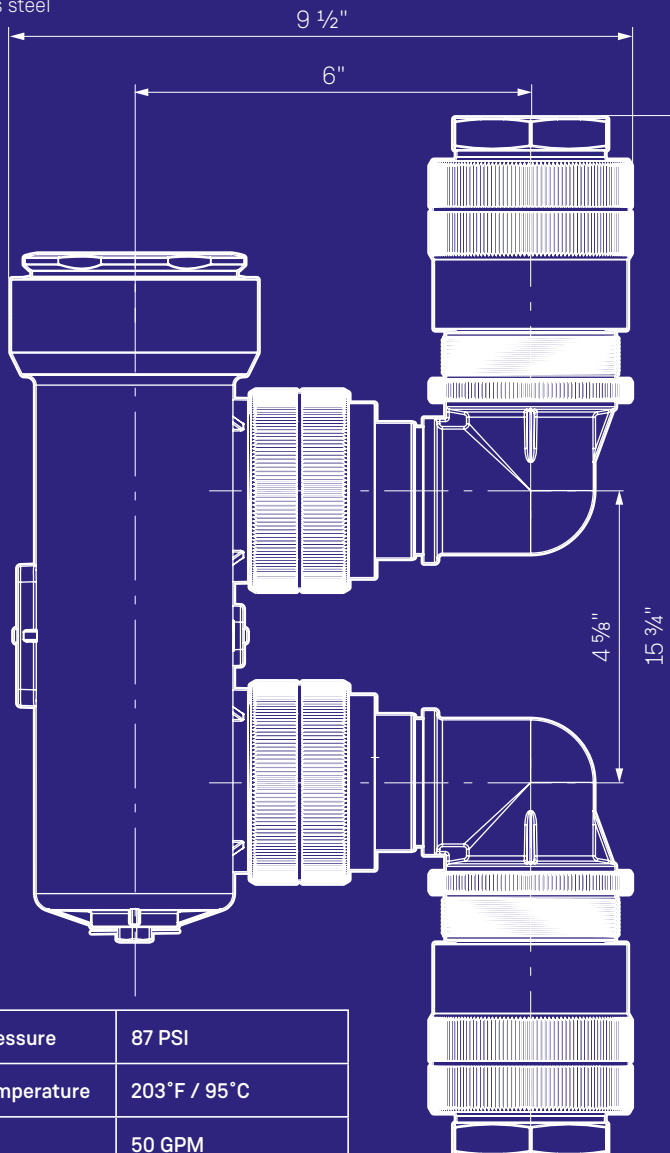

Max working pressure	87 PSI
Max working temperature	203°F / 95°C
Flow rate	50 GPM
Weight	18 lbs 2 oz

Full installation instructions are supplied with each filter and are also available to download from adey.com/us

Pressure drop flow graph

For the *MagnaClean DualXP* product flow rates, see the graph below.

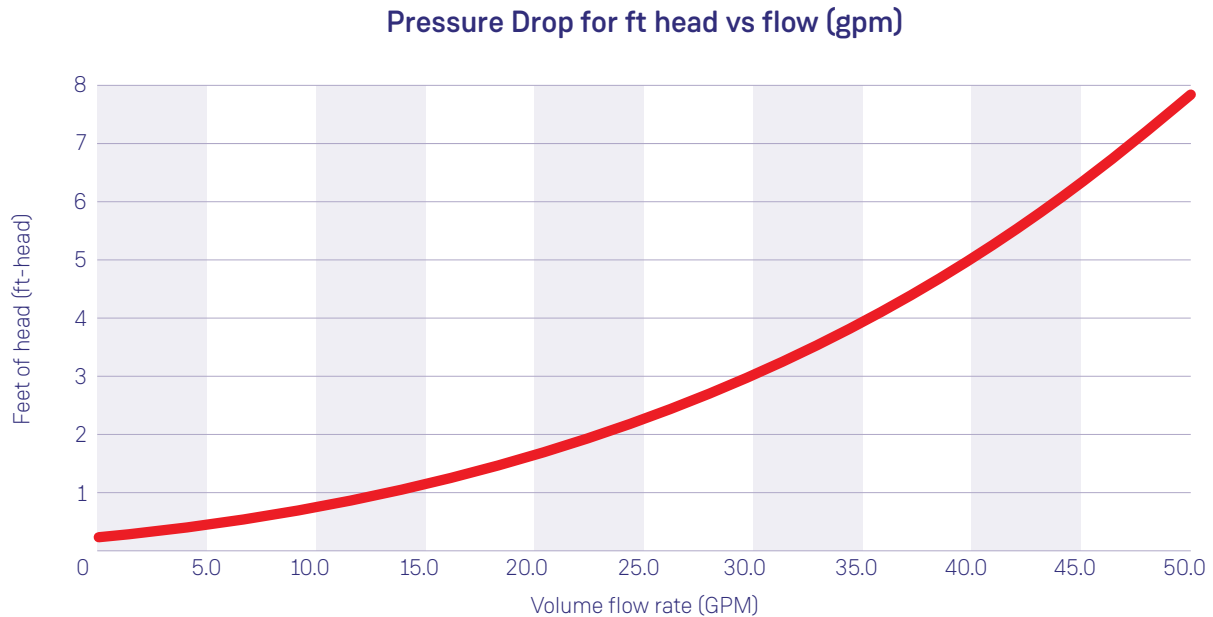

Any installation orientation

Telescopic connectors make installation easier in any orientation. These versatile connectors also make retro-fitting far more straightforward. For existing installations, the *MagnaClean DualXP*'s inherent retrofit characteristics make installation quicker, saving time and money.

The introduction of the dual magnetic chambers also enables a much smaller installation envelope making it easier for installers and contractors, without compromising filter performance. Another advantage of dual chambers is easier water treatment dosing of the system via the filter.



MagnaClean commercial and industrial filters

The larger the system, the larger the problem.

Whether it's cooling systems, steam systems or boiler systems, space restricted mechanical rooms or large industrial plants, in-line or side-stream installations, ADEY's commercial and industrial filters provide a solution for all types of hydronic applications.

The first of those ranges is *MagnaClean Commercial*. A range of 2, 3, 4, 6 & 8" 304L stainless steel filters with numerous large magnets in the flow of water, designed to clean and protect systems with known components failures/issues, and signs of corrosion.

The second range, *MagnaClean DRX*, is available in 2, 3 & 4", is a compact and versatile filtration option, offering preventative corrosion maintenance and protection for mechanical rooms with limited space.

Last but not least is *MagnaClean CMX*. This newest range provides adaptive side-stream magnetic and non-magnetic debris filtration for commercial and industrial hydronic systems that cannot be shutdown for servicing.

ADEY recognizes that engineers and service contractors want to offer their customers quality products and peace of mind for their long-term investment. This is why ADEY has a commitment to providing the highest quality components in every product.

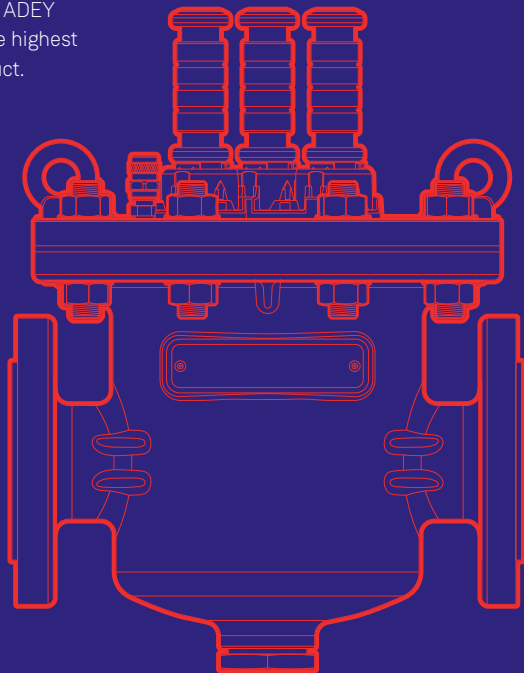
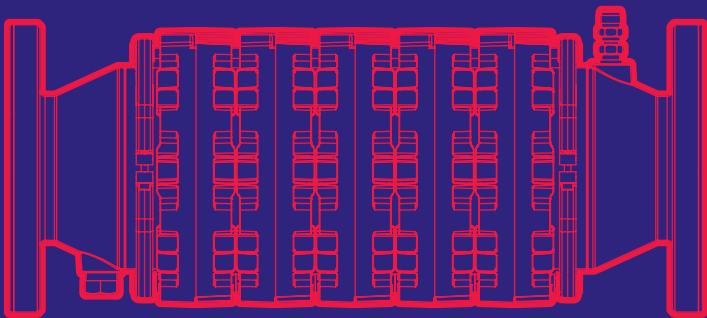
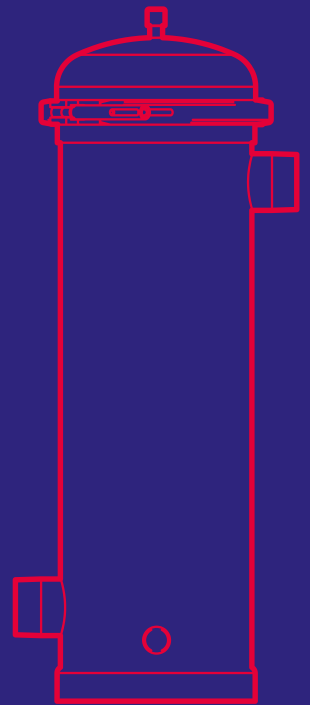

MagnaClean® Commercial

MagnaClean Commercial's 2", 3", 4", 6" and 8" range provides powerful protection for large commercial through to heavy industrial applications where corrosion is a known issue.

MagnaClean Commercial's large NdFeB magnetic rods not only maximize capture, but also make servicing far easier. The rods can be pulled up during servicing meaning the contractor never comes into contact with magnetite.

Engineered to ASME standards, the single cast 304L stainless steel moldings and EPDM seals ensure robust sealing at high temperatures.

Features and Benefits

- Construction conforms to ASME standards and is CRN approved
- Multiple neodymium magnets directly in flow of water for maximum magnetite collection
- Individually adjustable magnets for easier, quicker and mess-free servicing
- Zero operational costs
- Protection of system equipment such as heat pumps, boilers, pipework, sensors/controls
- Extended component and system life
- Reduced maintenance costs
- Improved heat transfer, heat output and efficiency
- Energy savings = lower utility bills
- Reduced carbon emissions
- EPDM seals for robust sealing at high temperatures
- EPDM seals compatible with amines in inhibitors to prevent degrading
- Helps restore heating system efficiency and performance
- Ongoing maintenance costs are reduced

Product codes:
2": FL1-03-02700
3": FL1-03-02701
4": FL1-03-02702
6": FL1-03-02703
8": FL1-03-02704

Accessories available:

- Thermal Jacket



ADEY Best Practice essentials:

MC3+® Hydronic System CLEANER - page 40
MC1+® Hydronic System PROTECTOR - page 43

Technical specifications

Commercial 2"

Casing

Material: 304L stainless steel
Drain point: 1/4" NPT hole, 1/4" NPT plug
Maximum working pressure: 145 PSI
Maximum working temperature: 212°F / 100°C

Magnets

Material: High power, NdFeB
Pocket sleeves: 304L Stainless steel
Lid seal: EPDM

Flow flange

Size: PN16, supplied with EPDM gasket
Flange thickness: 11/16"
Bolt size: 5/8"
Bolt quantity: 4
Bolt hole PCD: 125

Weld material: DIN1.4404 stainless steel
Collar nut: DIN1.4301/DIN1.4307 stainless steel
Product side seal: EPDM
Outer seal: Non-asbestos fibre (KILINGERSil C-4400)

Full installation instructions are supplied with each filter and are also available to download from adey.com

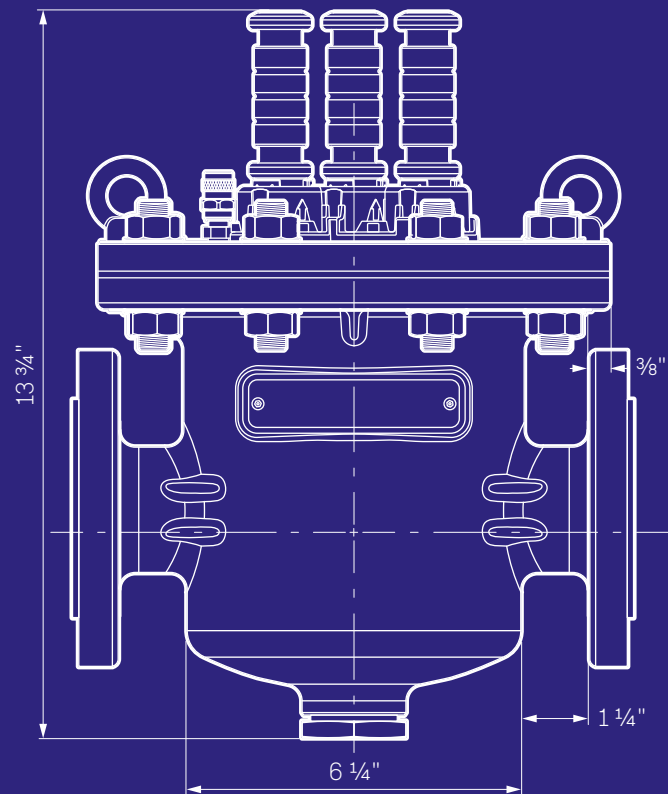
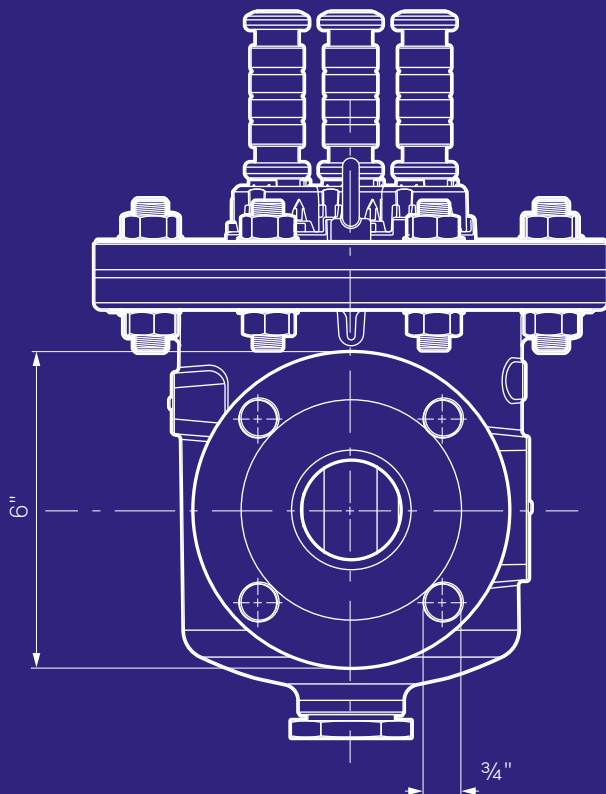
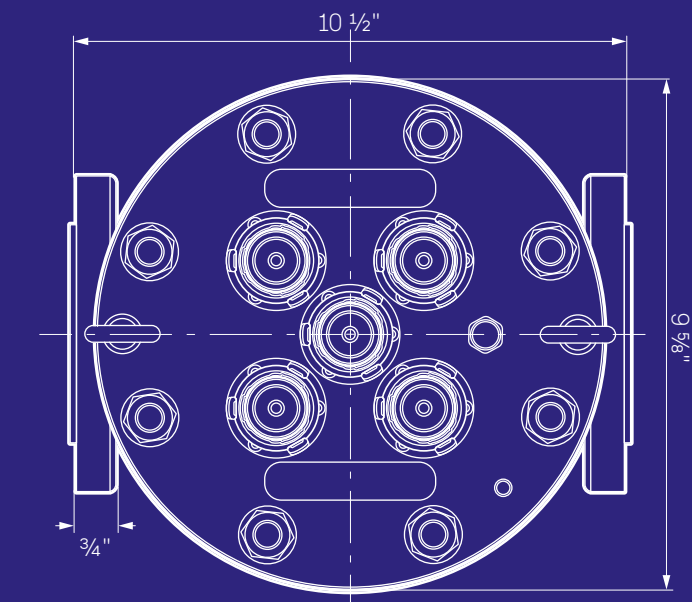

Technical specifications

Commercial 3"

Casing

Material: 304L stainless steel
Drain point: 1¼" NPT hole, 1¼" NPT plug
Maximum working pressure: 145 PSI
Maximum working temperature: 212°F / 100°C

Magnets

Material: High power, NdFeB
Pocket sleeves: 304L Stainless steel
Lid seal: EPDM

Flow flange

Size: PN16, supplied with EPDM gasket
Flange thickness: 5/8"
Bolt size: 5/8"
Bolt quantity: 8
Bolt hole PCD: 160

Weld material: DIN1.4404 stainless steel
Collar nut: DIN1.4301/DIN1.4307 stainless steel
Product side seal: EPDM
Outer seal: Non-asbestos fibre (KILINGERSil C-4400)

Full installation instructions are supplied with each filter and are also available to download from adey.com

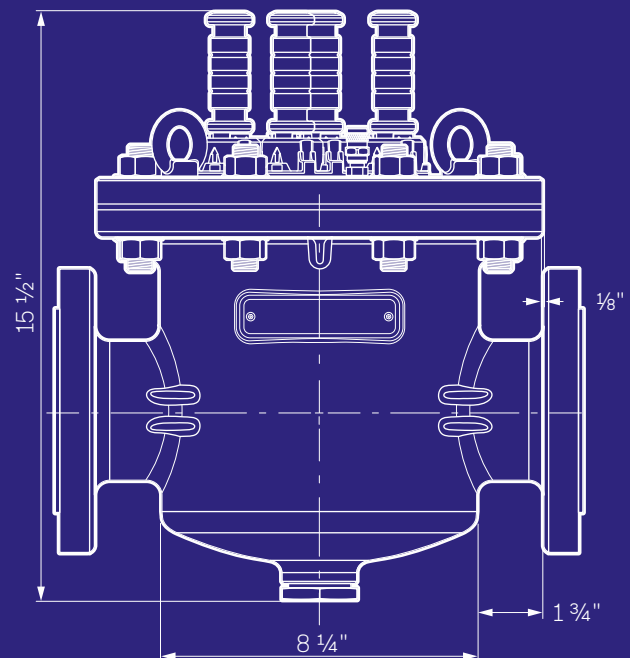
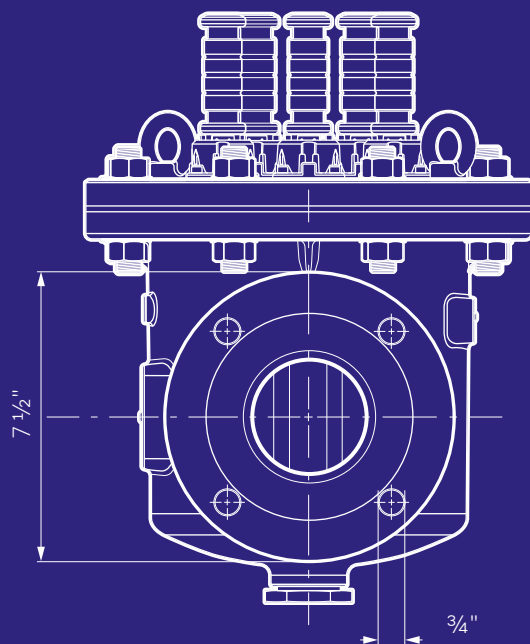
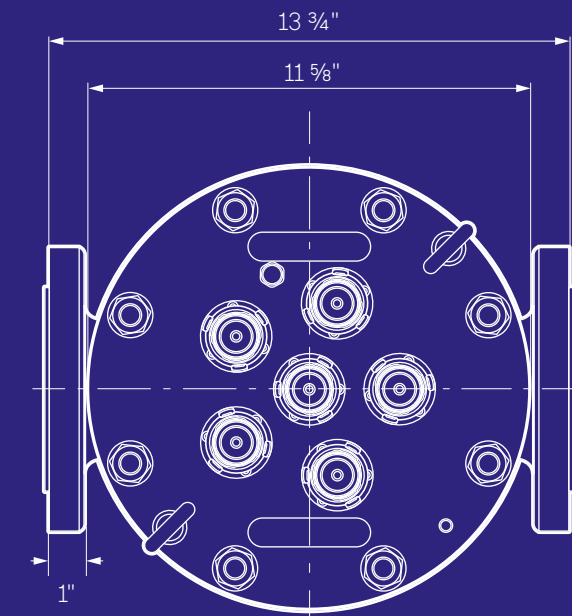

Technical specifications

Commercial 4"

Casing

Material: 304L stainless steel
Drain point: 1¼" NPT hole, 1¼" NPT plug
Maximum working pressure: 145 PSI
Maximum working temperature: 212°F / 100°C

Magnets

Material: High power, NdFeB
Pocket sleeves: 304L Stainless steel
Lid seal: EPDM

Flow flange

Size: PN16, supplied with EPDM gasket
Flange thickness: 19/32"
Bolt size: 5/8"
Bolt quantity: 8
Bolt hole PCD: 180

Weld material: DIN1.4404 stainless steel
Collar nut: DIN1.4301/DIN1.4307 stainless steel
Product side seal: EPDM
Outer seal: Non-asbestos fibre (KILINGERSil C-4400)

Full installation instructions are supplied with each filter and are also available to download from adey.com

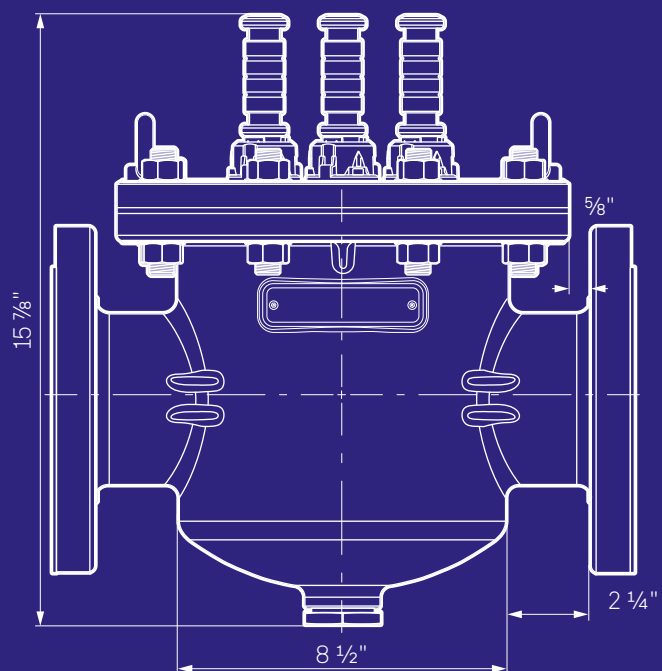
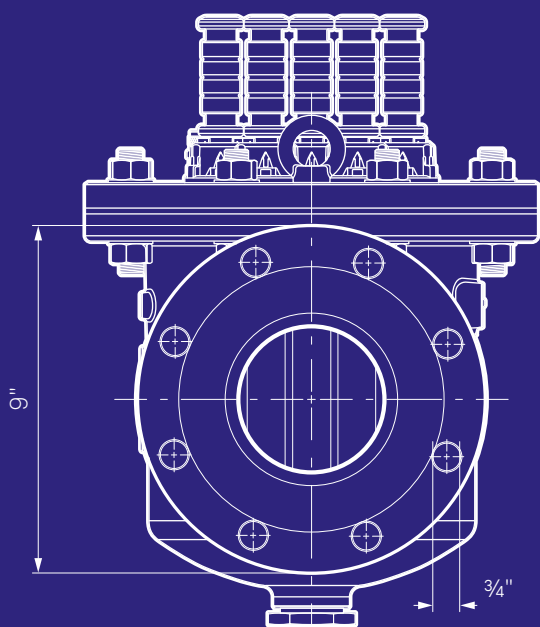
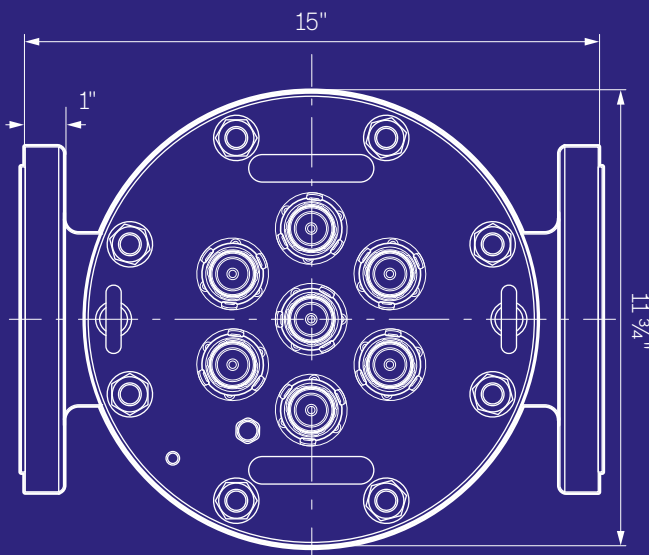

Technical specifications

Commercial 6"

Casing

Material: 304L stainless steel
Drain point: 1¼" NPT hole, 1¼" NPT plug
Maximum working pressure: 145 PSI
Maximum working temperature: 212°F / 100°C

Magnets

Material: High power, NdFeB
Pocket sleeves: 304L Stainless steel
Lid seal: EPDM

Flow flange

Size: PN16, supplied with EPDM gasket
Flange thickness: 1½"
Bolt size: ¾"
Bolt quantity: 8
Bolt hole PCD: 240

Weld material: DIN1.4404 stainless steel
Collar nut: DIN1.4301/DIN1.4307 stainless steel
Product side seal: EPDM
Outer seal: Non-asbestos fibre (KILINGERSil C-4400)

Full installation instructions are supplied with each filter and are also available to download from adey.com

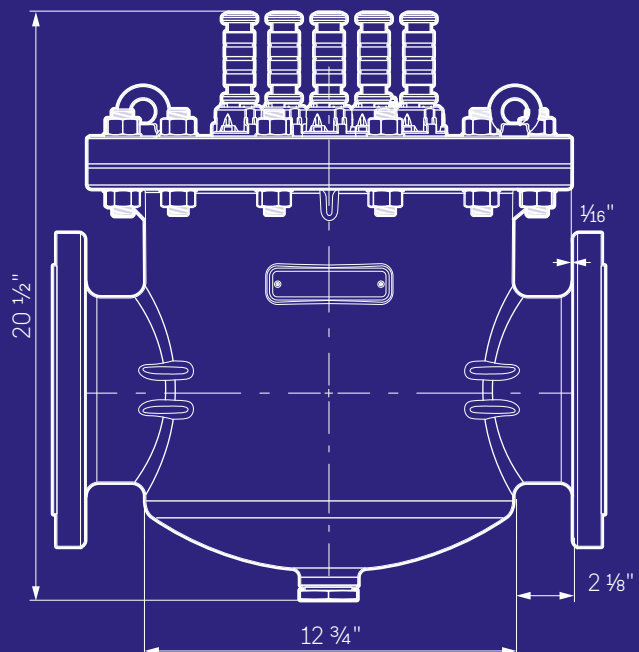
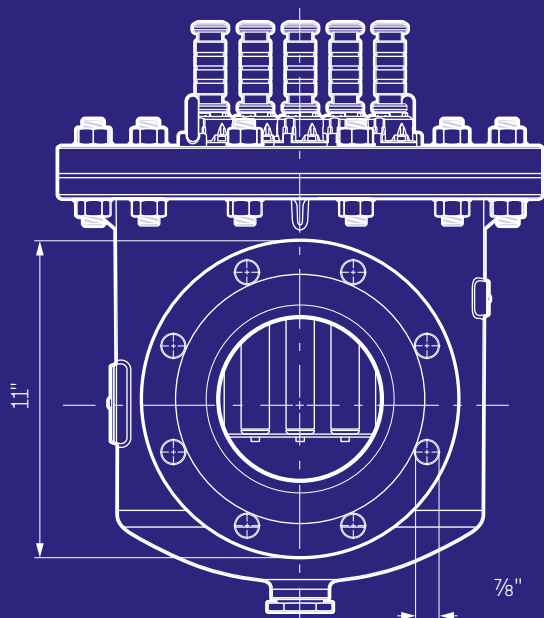
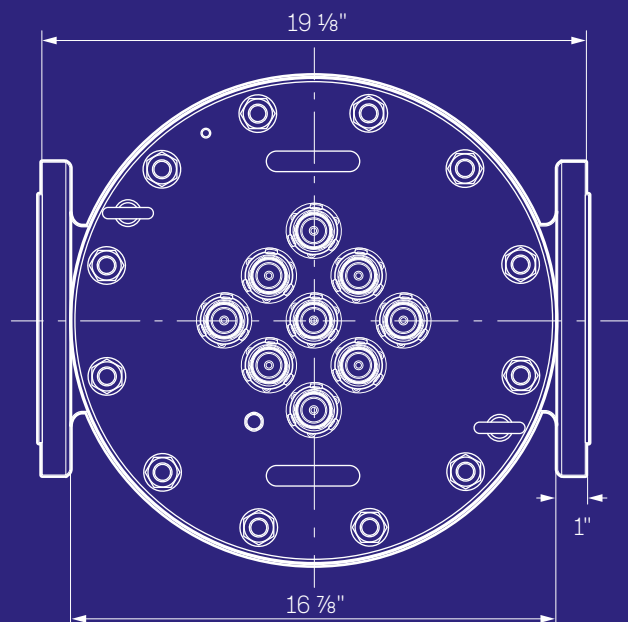

Technical specifications

Commercial 8"

Casing

Material: 304L stainless steel
Drain point: 1/4" NPT hole, 1/4" NPT plug
Maximum working pressure: 145 PSI
Maximum working temperature: 212°F / 100°C

Magnets

Material: High power, NdFeB
Pocket sleeves: 304L Stainless steel
Lid seal: EPDM

Flow flange

Size: PN16, supplied with EPDM gasket
Flange thickness: 3/4"
Bolt size: M20
Bolt quantity: 12
Bolt hole PCD: 295

Weld material: DIN1.4404 stainless steel
Collar nut: DIN1.4301/DIN1.4307 stainless steel
Product side seal: EPDM
Outer seal: Non-asbestos fibre (KILINGERSil C-4400)

Full installation instructions are supplied with each filter and are also available to download from adey.com

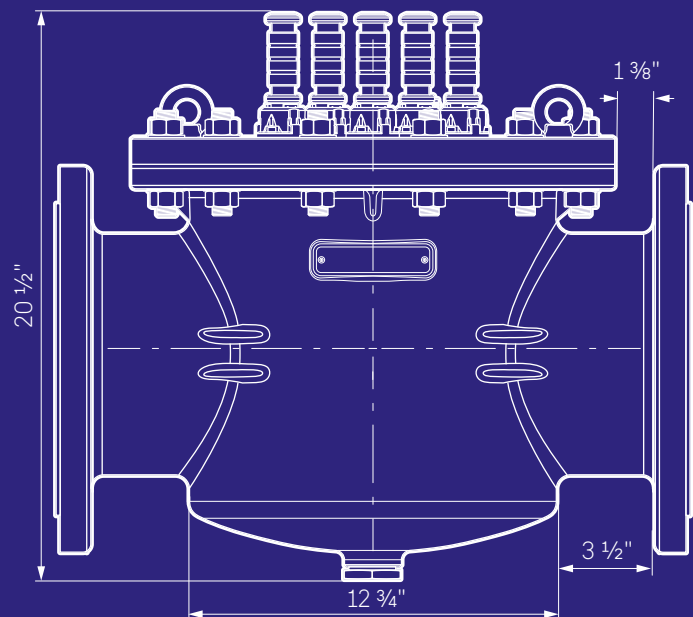
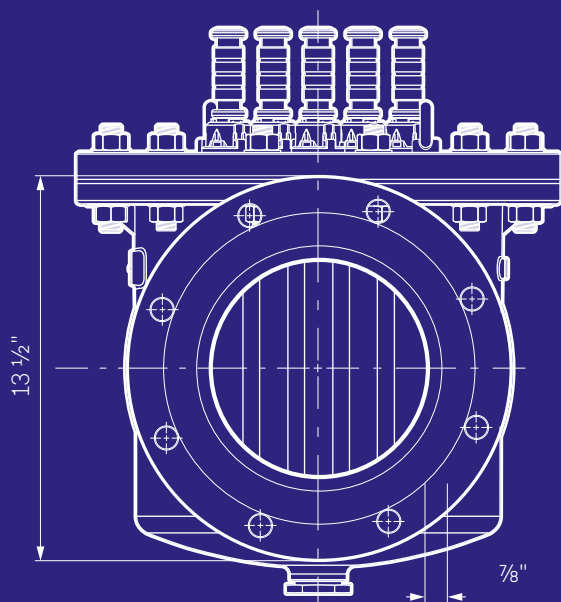
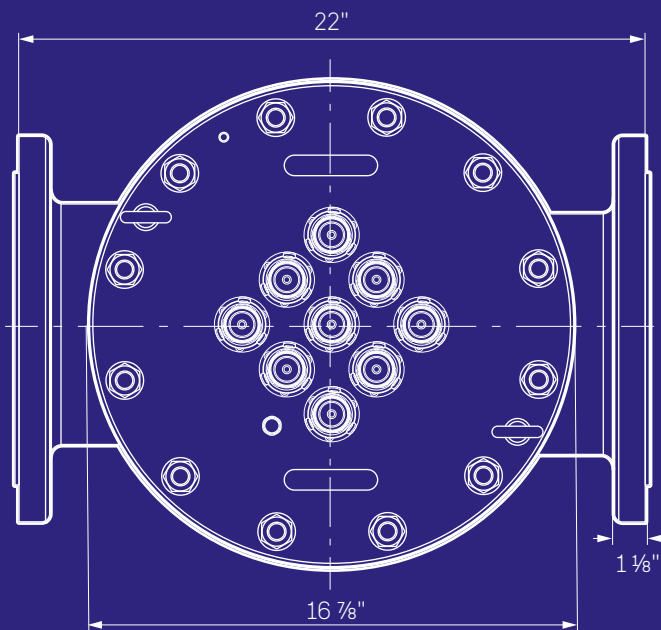

Pressure drop flow graphs

For the *MagnaClean Commercial* product flow rates, see the graphs below:

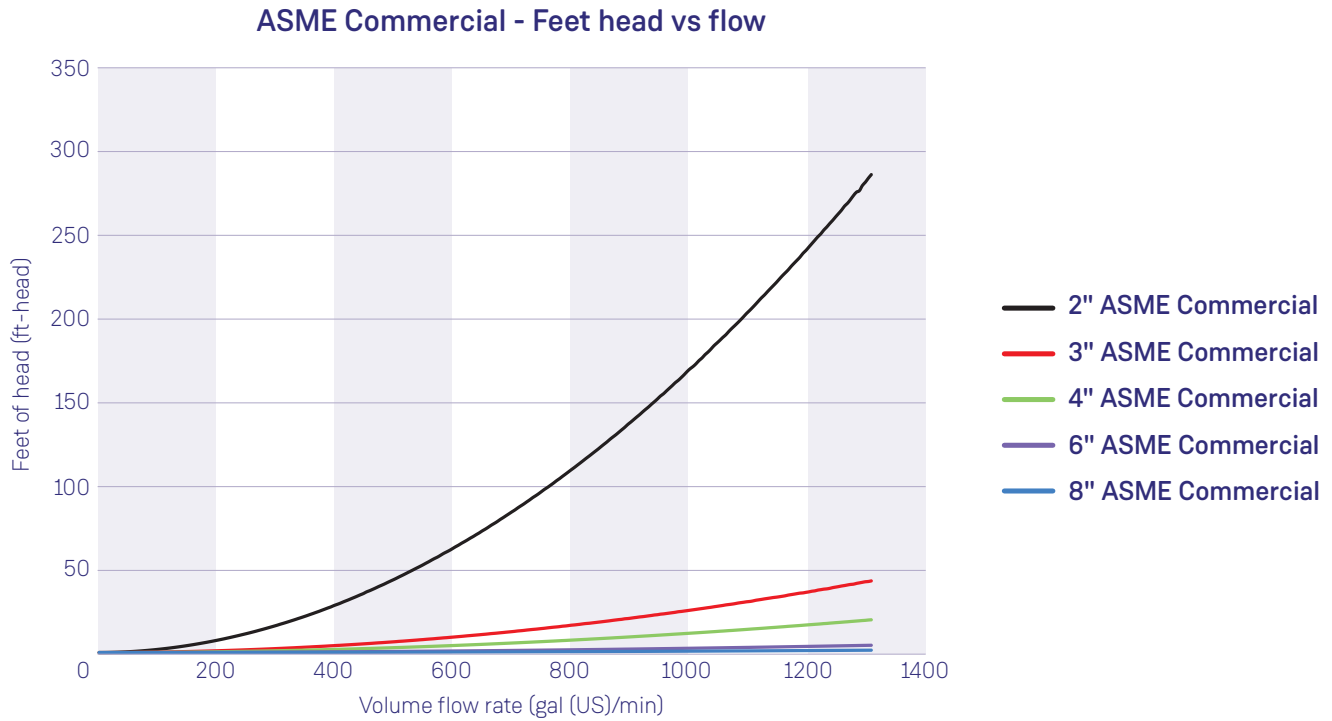

MagnaClean[®]

DRX



The ADEY *MagnaClean DRX*[®] magnetic dirt filter provides essential protection for commercial boiler systems with limited space. The filter consists of an innovative magnetic belt, containing numerous high-performing neodymium magnets, wrapped around a precision-engineered stainless-steel canister that simply unclips for easy servicing.

ASME and CRN approved, the *DRX* is available to suit 2", 3", and 4" pipe sizes and is supplied with ANSI B.150 flanges with EPDM rubber gaskets for robust sealing at high temperatures.

Features and Benefits

- Compatible with 2", 3" & 4" hydronic heating systems
- Product includes numerous neodymium magnets per filter (2"- 48 magnets, 3"- 64 magnets, 4"- 80 magnets): ensuring effective capture of magnetite, through the stainless-steel wall of the canister
- Vertical or Horizontal Installation without any additional material costs required
- Lightweight One person install = reduced labor costs
- Cost-effective: Allows specifiers to deliver more competitive quotes, and contractors to meet spec at a more affordable cost
- Patented design ensures low pressure loss
- "Spring-loaded" magnets: Ensures magnets align properly with canister, maximizing capture
- Suitable for in-line and side stream installations
- Protection of system equipment such as pumps, boilers, pipework, sensors/controls
- Extended component and system life
- Reduced maintenance costs
- Improved heat transfer, heat output and efficiency

Accessories available:

- Automatic Air Vent
- Thermal Jacket

Product codes:

2": FL1-03-03784 3": FL1-03-03785 4": FL1-03-03786

ADEY Best Practice essentials:

MC3+[®] Hydronic System CLEANER - page 40

MC1+[®] Hydronic System PROTECTOR - page 43

Technical specifications

DRX 2"

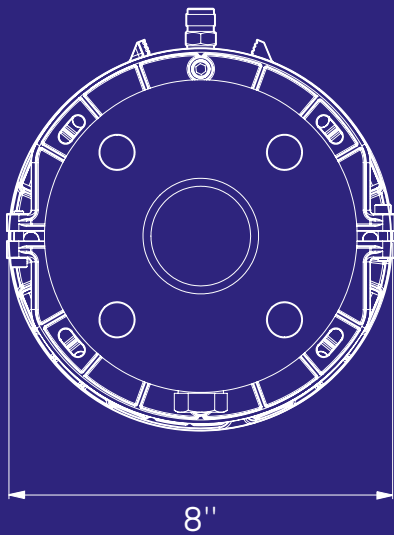
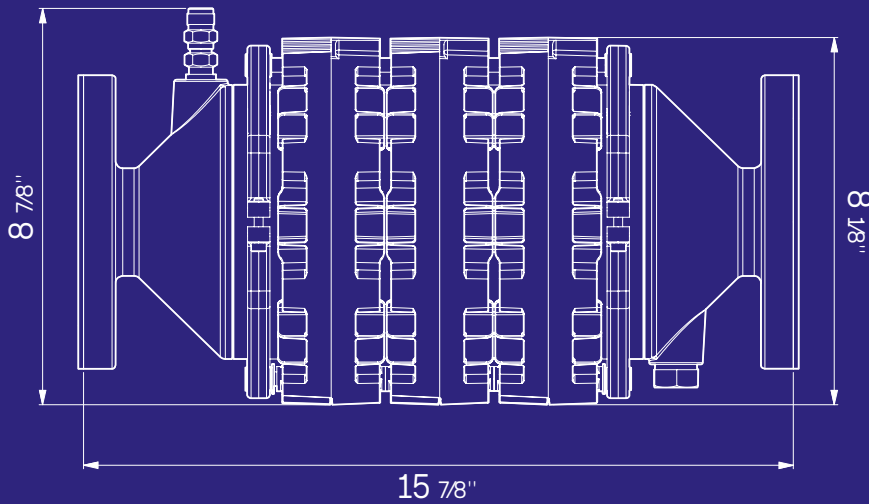

Casing

Material: Stainless steel
Volume Gallons (approx): 1.3 gallons
Flow Configuration: In-Line or Side Stream
Seals: EDPM Flange gaskets
Drain point thread: 3/4" NPT
Maximum working pressure: 232 PSI
Maximum working temperature: 212°F / 100°C
Air vent: Manual. Auto available

Total unit weight

2": 24.5 lbs

Magnet Assembly

Casing: Glass reinforced nylon
Magnets - type: Neodymium
Magnets - number of: 48
Magnets - dimensions: 3/4" Dia x 1/2" Thk

Flow flange ANSI

Flange diameter: 6"
Flange thickness: 3/4"
Flange type: PN16 (B16.5 Class 150)
Bolt size: 5/8"
Bolt quality: 4
Bolt hole PCD: 4 3/4"

Full installation instructions are supplied with each filter and are also available to download from adey.com/us

Technical specifications

DRX 3"

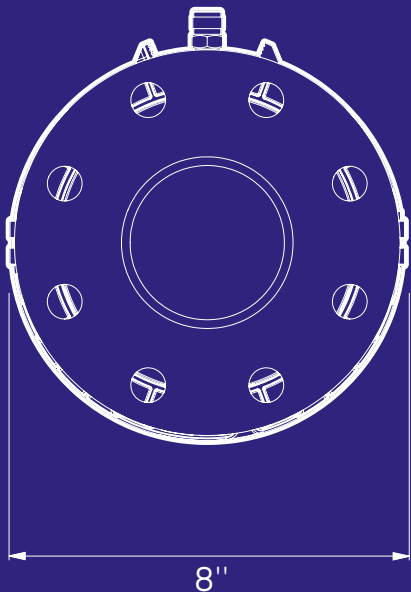
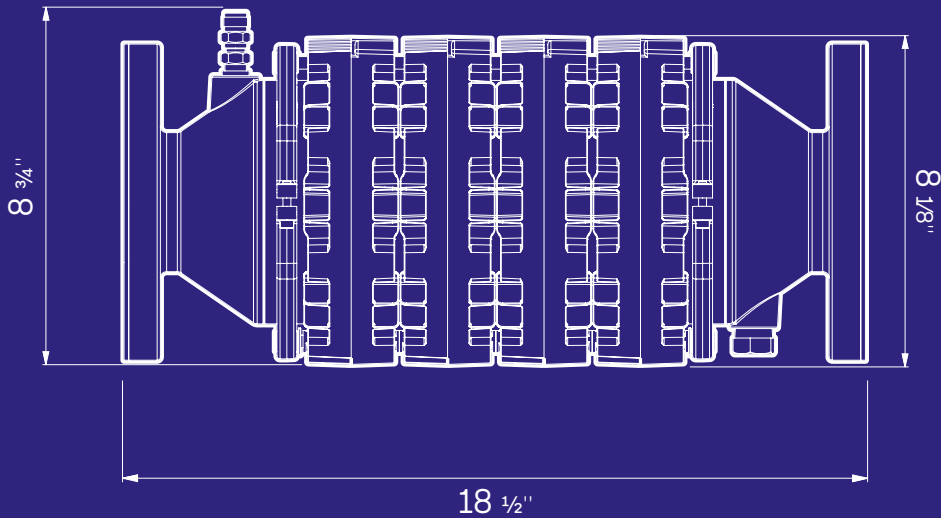

Casing

Material: Stainless steel
Volume Gallons (approx): 1.7 gallons
Flow Configuration: In-Line or Side Stream
Seals: EDPM Flange gaskets
Drain point thread: 3/4" NPT
Maximum working pressure: 232 PSI
Maximum working temperature: 212°F / 100°C
Air vent: Manual. Auto available

Total unit weight

3": 36.2 lbs

Magnet Assembly

Casing: Glass reinforced nylon
Magnets - type: Neodymium
Magnets - number of: 64
Magnets - dimensions: 3/4" Dia x 1/2" Thk

Flow flange ANSI

Flange diameter: 7 1/2"
Flange thickness: 1"
Flange type: PN16 (B16.5 Class 150)
Bolt size: 5/8"
Bolt quality: 8
Bolt hole PCD: 6"

Full installation instructions are supplied with each filter and are also available to download from adey.com/us

Technical specifications

DRX 4"

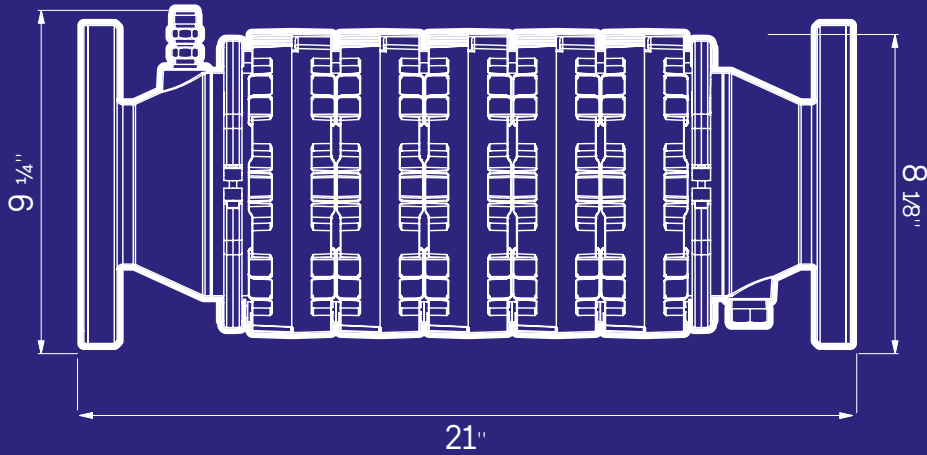

Casing

Material: Stainless steel
Volume Gallons (approx): 2 gallons
Flow Configuration: In-Line or Side Stream
Seals: EDPM Flange gaskets
Drain point thread: 3/4" NPT
Maximum working pressure: 232 PSI
Maximum working temperature: 212°F / 100°C
Air vent: Manual. Auto available

Total unit weight

4": 46.1 lbs

Magnet Assembly

Casing: Glass reinforced nylon
Magnets - type: Neodymium
Magnets - number of: 80
Magnets - dimensions: 3/4" Dia x 1/2" Thk

Flow flange ANSI

Flange diameter: 9"
Flange thickness: 1"
Flange type: PN16 (B16.5 Class 150)
Bolt size: 5/8"
Bolt quality: 8
Bolt hole PCD: 7 1/2"

Full installation instructions are supplied with each filter and are also available to download from adey.com/us

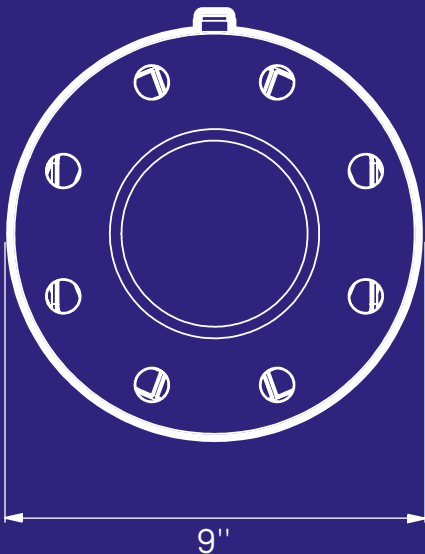

Pressure drop flow graphs

For the *MagnaClean DRX* product flow rates, see the graphs below:

ASME DRX - Feet head vs flow

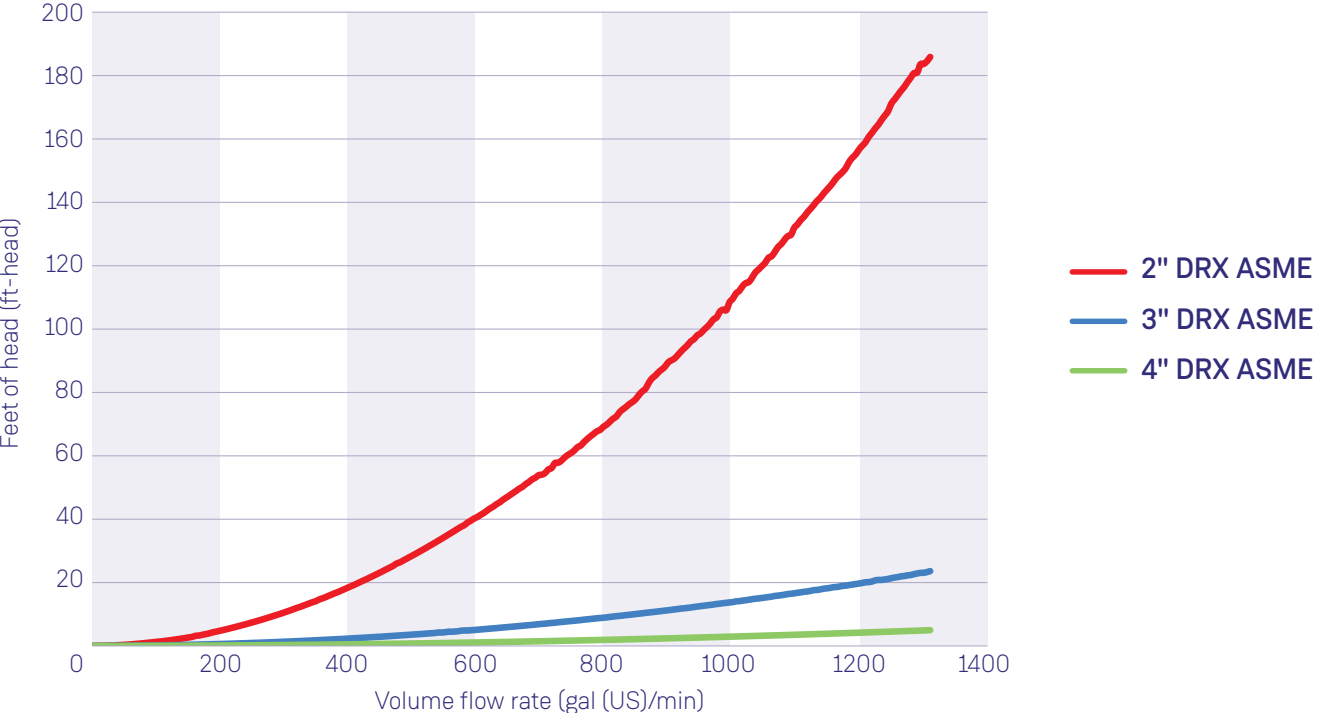

MagnaClean[®]

CMX

The *MagnaClean CMX™* range offers a new and unique way of capturing both magnetic and non-magnetic debris in a side-stream configuration by combining powerful neodymium magnets with a range of high quality, 5-50 micron spun-bonded filter cartridges, and depending on the size chosen, a needlefelt bag filter or stainless basket strainer, while also offering pot feeder capabilities.

Features and Benefits

- Available in 1" and 2" NPT
- Adaptive filtration - magnetic, non-magnetic, or combined
- 316L stainless unit with 304 stainless clamp assembly
- Compact and lightweight solution
- Powerful Neodymium magnets
- Spun-bonded cartridge filters (5-50-micron)
- Needlefelt bag filters (5 - 50 micron)
- Max working pressure: 145 PSI
- Temp range: -10°C / 14°F to 150°C / 302°F
- Midi and Maxi act as chemical dosing pots / pot feeders = easier water treatment management
- Cartridge filters aid air removal via automatic air vent
- Side-stream = reduced installation time, complexity & costs
- Ideal for applications that can't be shut down for servicing: sports facilities, manufacturing plants, hospitals, etc.
- Floor-standing options
- Tool-free servicing and removable magnet assemblies, making it easy to install and service
- CMX Nano external magnetic jacket = most compact, yet powerful commercial system filter combination available today



Product codes:

Nano 1" NPT: FL1-03-05010-US

Midi 2" NPT: FL1-03-05013-US

Maxi 2" NPT: FL1-03-05014-US

Nano magnetic thermal jacket: FL1-03-05667

5-Micron Cartridge Filters PK2-03-05254

10-Micron Cartridge Filters PK2-03-05255

20-Micron Cartridge Filters PK2-03-05256

50-Micron Cartridge Filters PK2-03-05257

5-Micron Bag Filters PK2-03-05258

10-Micron Bag Filters PK2-03-05259

25-Micron Bag Filters PK2-03-05260

50-Micron Bag Filters PK2-03-05261

ADEY Best Practice essentials:

MC3+[®] Hydronic System CLEANER - page 40
MC1+[®] Hydronic System PROTECTOR - page 43

	MagnaClean CMX Nano	MagnaClean CMX Midi	MagnaClean CMX Maxi
Neodymium Magnets	1 ✓	3 ✓	4 ✓
Spun-bonded Cartridge	1 ✓	3 ✓	✗
Needlefelt Bag Filter	✗	✗	1 ✓
Stainless Steel Basket Strainer	✗	✗	1 ✓

Technical specifications

CMX Nano

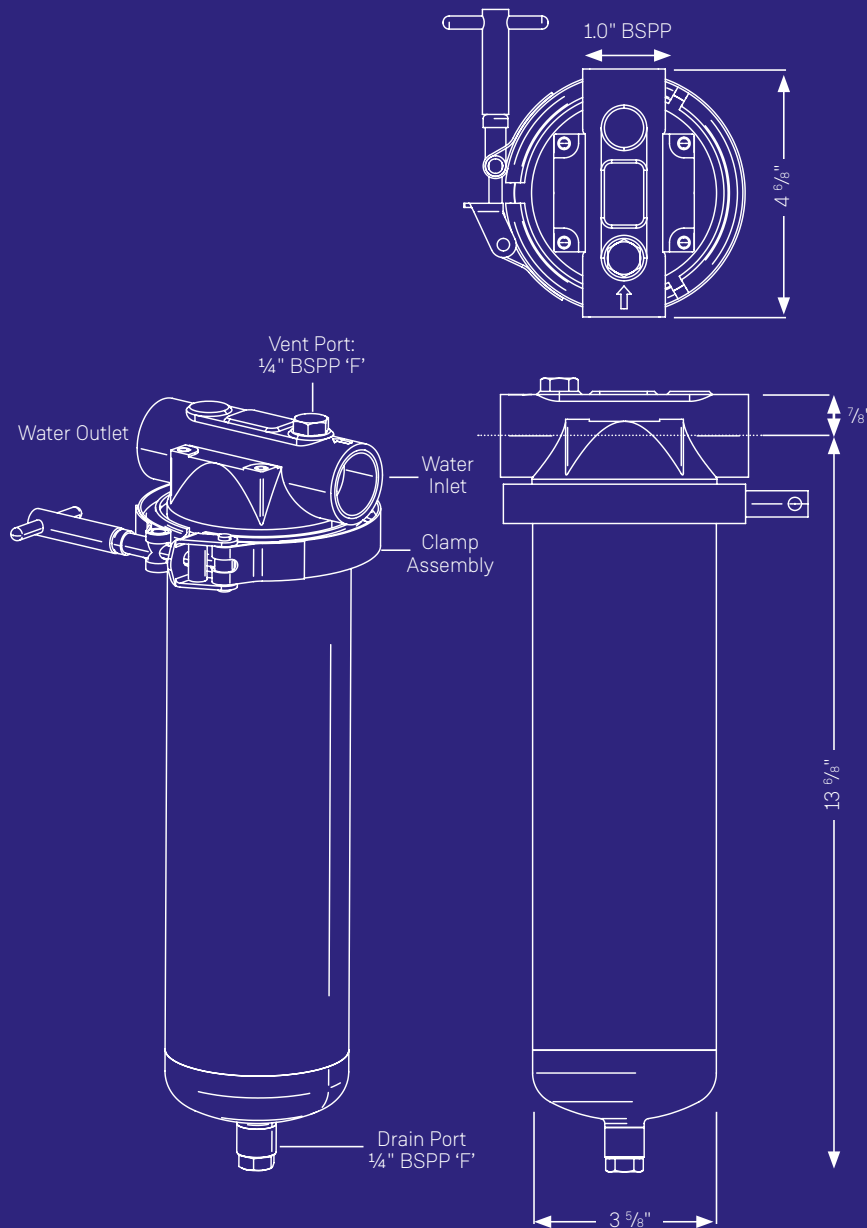

Technical Data

Filter body & lid: 316L Stainless Steel
Body finish: Polished
Flow Configuration: Side Stream
Dry weight: 6.6lbs
Filter head: Bead Blast
Internal compression nut: 316L Stainless Steel
O-Ring seal: EPDM
Clamp and Tee-Bar: 304 Stainless Steel
Drain port: 316L Stainless Steel
Plug & O-Ring: 316L Stainless Steel & PTFE
Magnets (x1): Neodymium rare-earth
Air vent body: CB754S Brass
Air vent float: PE
Air vent spring: Stainless steel
Cartridge filters 5-50 μm (x1): Spun-bonded polypropylene

Performance

Suitable fluids: water, ADEY chemicals
Max. percentage of glycol: 50%
Max. working pressure: 145 psi (10 bar)
Temperature range: 14–302°F (-10–150°C)
Maximum temperature with packaged air vent:
230°F (110°C)
Particle separation capacity: down to 5 μm
(0.2 mil)
Inlet & Outlet Connections: 1" BSPP F with 1" NPT
M Adapter
Vent port: 1/4" BSP Female with BSPP Plug & PTFE
O-Ring
Drain port: 1/4" BSPP Female with BSPP Plug &
PTFE O-Ring
Flow rate: 7.9 g/pm with cartridge filter installed

Full installation instructions are supplied with each filter and are also available to download from adey.com/us

Technical specifications

CMX Midi

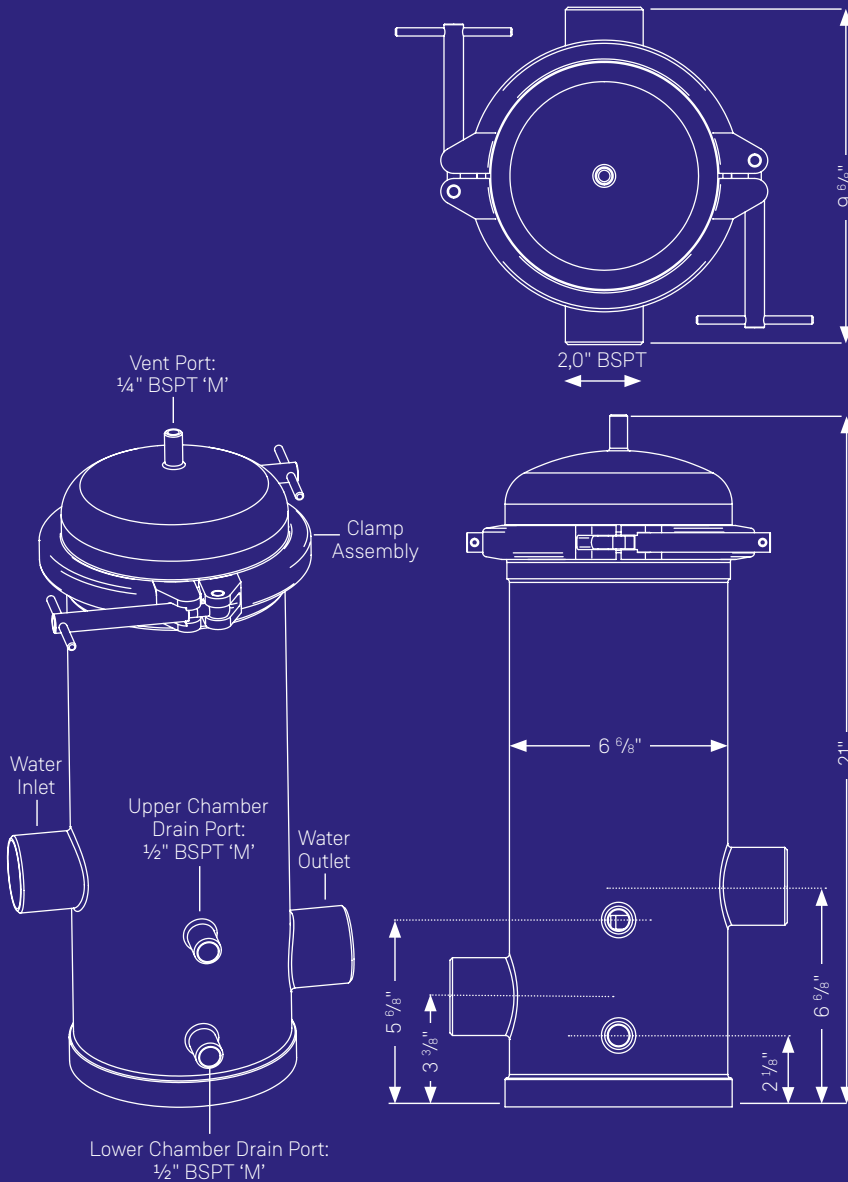

Technical Data

Filter body & lid: 316L Stainless Steel
 Body & lid finish: Polished
 Flow Configuration: Side Stream
 Dry weight: 25.1lbs
 Gasket seal: EPDM
 Center rod top section: 316L Stainless Steel
 Spring & seal assembly: 316L Stainless Steel
 Compression plate assembly: 316L Stainless Steel
 Compression nut & washer: 316L Stainless Steel
 Clamp & tee-bars: 304 Stainless Steel
 Blanking caps: 316L Stainless Steel
 Magnets (x3): Neodymium rare-earth
 Air vent body: CB754S Brass
 Air vent float: PE
 Air vent spring: Stainless steel
 Cartridge Filters 5-50 μm (x3): Spun-bonded polypropylene. Micron sizes can be mixed, e.g. 2 x 20 μm & 1 x 50 μm

Performance

Suitable fluids: water, ADEY chemicals
 Max. percentage of glycol: 50%
 Max. working pressure: 145 psi (10 bar)
 Temperature range: 14-302°F (-10-150°C)
 Maximum temperature with packaged air vent: 230°F (110°C)
 Particle separation capacity: down to 5 μm (0.2 mil)
 Inlet & Outlet Connections: 2" BSPT M with 2" NPT F Adapter
 Vent port: 1/4" BSPT Male with BSPT Plug
 Drain ports: 1/2" BSPT Male with BSPT Plug
 Flow rate: 17.2 g/pm with cartridge filters installed

Full installation instructions are supplied with each filter and are also available to download from adey.com/us

Technical specifications

CMX Maxi

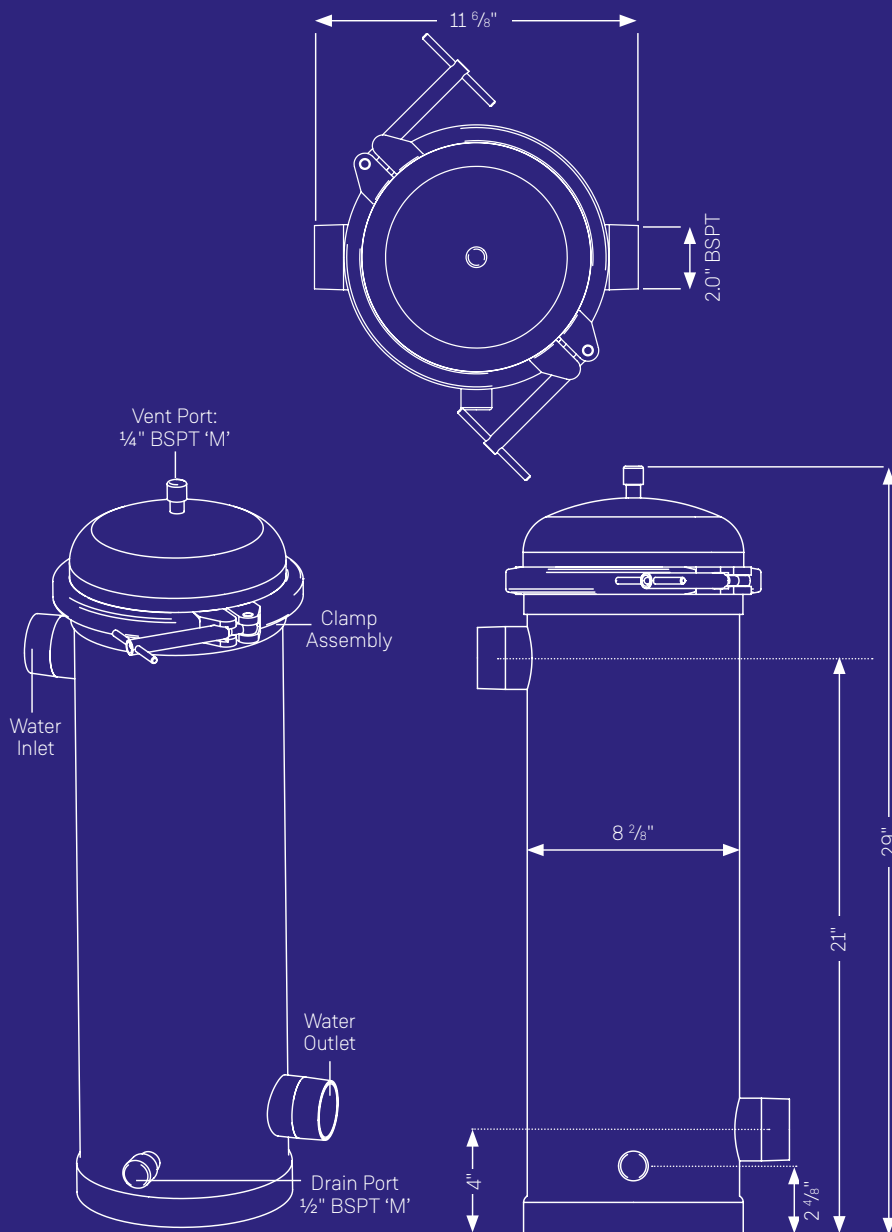

Technical Data

Filter body & lid: 316L Stainless Steel
Body & lid finish: Polished
Flow Configuration: Side Stream
Dry weight: 38.5lbs
Gasket seal: EPDM
Basket filter: 316L Stainless Steel
Basket compression plate: 316L Stainless Steel
Inner basket gasket: EP
Clamp & tee-bars: 304 Stainless Steel
Blanking caps: 316L Stainless Steel
Magnets (x4): Neodymium rare-earth
Air vent body: CB754S Brass
Air vent float: PE Air vent spring: Stainless steel
Bag filter 5-50 μm (x1): Polypropylene Needlefelt

Performance

Suitable fluids: water, ADEY chemicals
Max. percentage of glycol: 50%
Max. working pressure: 145 psi (10 bar)
Temperature range: 14-302°F (-10-150°C)
Maximum temperature with packaged air vent: 230°F (110°C)
Particle separation capacity: down to 5 μm (0.2 mil)
Inlet & Outlet Connections: 2" BSPT M with 2" NPT F Adapter
Vent port: 1/4" BSPT Male with BSPT Plug
Drain ports: 1/2" BSPT Male with BSPT Plug
Flow rate: 59.4 g/pm with bag filter installed

Full installation instructions are supplied with each filter and are also available to download from adey.com/us

Pressure drop flow graphs

For the *MagnaClean CMX* product flow rates, see the graphs below:

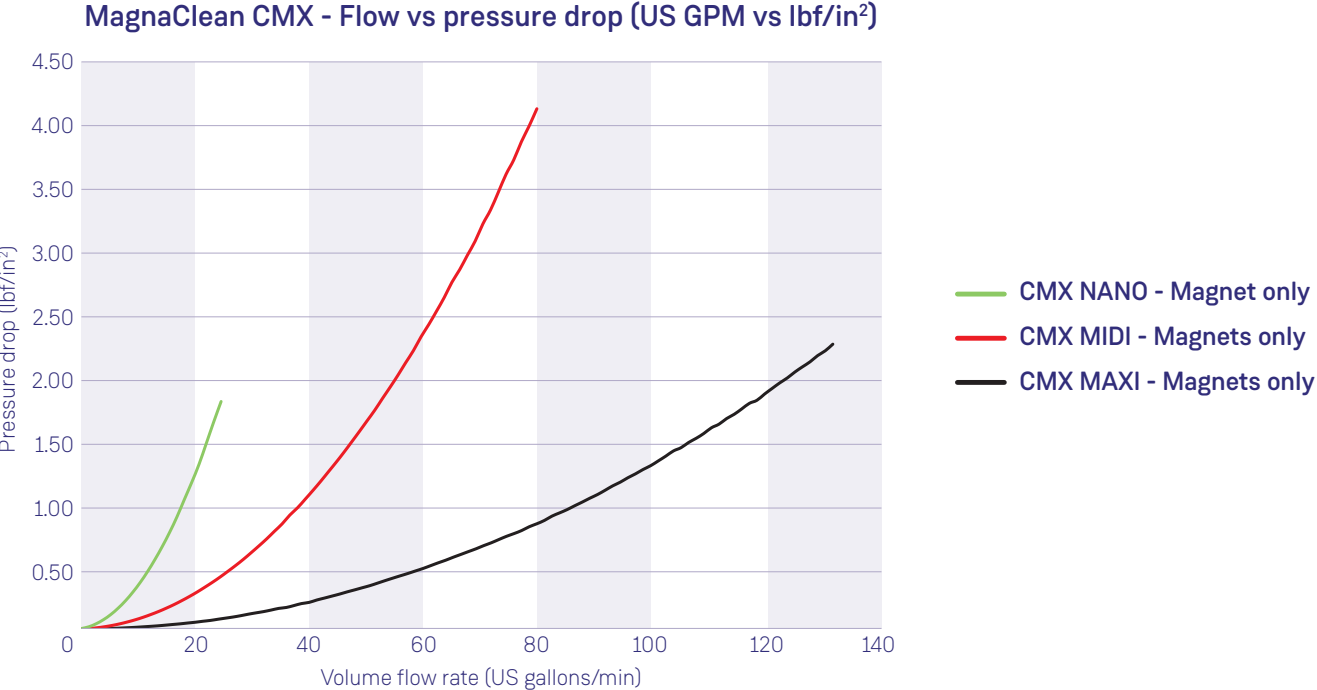

Award winning water treatment products

ADEY's award winning MagnaClean magnetic filters and range of water treatment chemicals have been designed to provide the ultimate solution for maintaining, protecting, and prolonging the life of hydronic heating and cooling systems.

The advanced MC+ water treatment range is formulated and tested in ADEY's very own in-house laboratories, ensuring complete quality control and assurance.

ADEY's product testing exceeds ten times the governing body standard and is one of the most tested product ranges on the market today.

With a mixture of sizes that treat both residential and commercial systems, a variety of cleaners designed to remove heavier scale and calcium deposits, down to sub-micron magnetic debris, and inhibitors to provide protection.

ADEY's range of formulas are also one of the most versatile ranges available in North America.

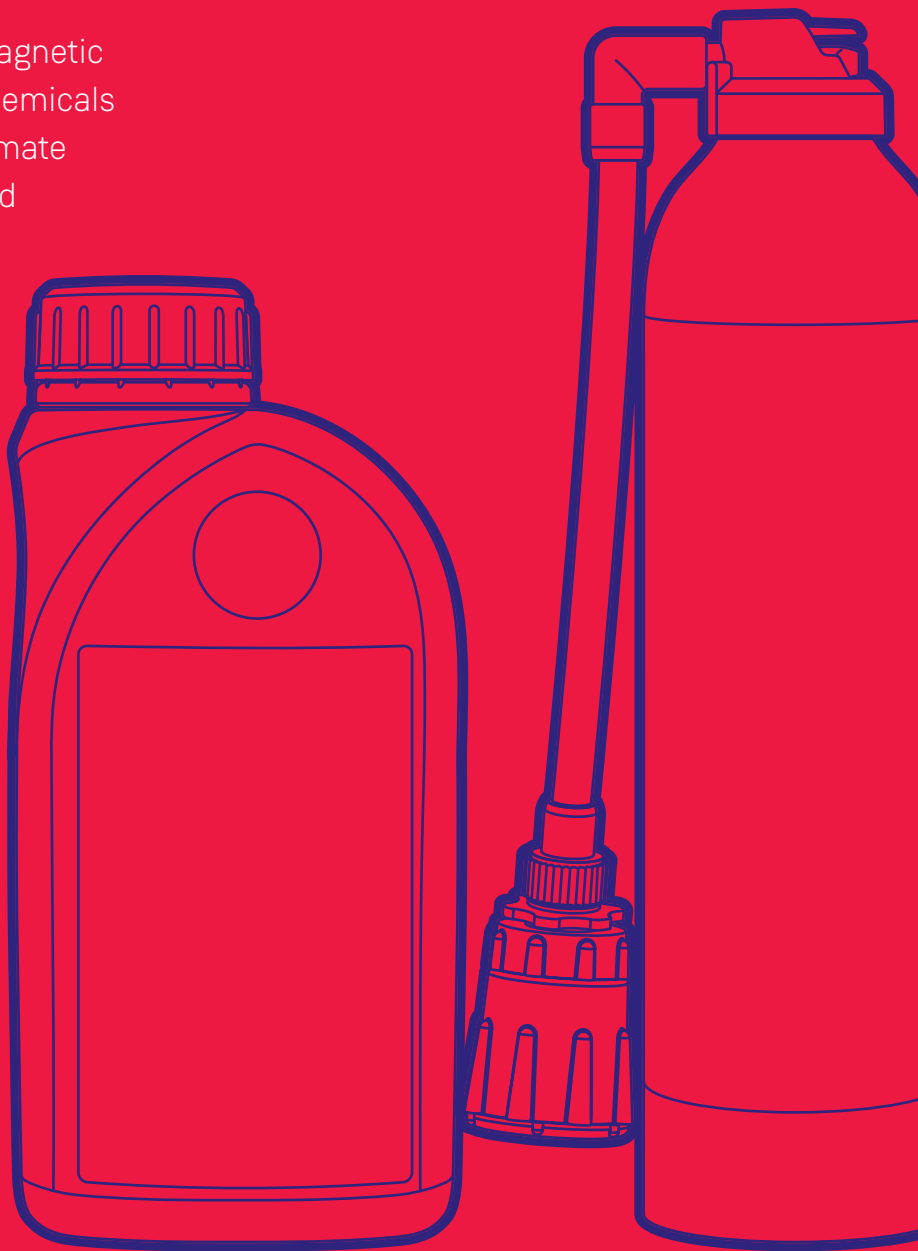

MC3+[®]

MC3+[®] *Rapide*

Hydronic Heating System CLEANER

MC3+[®] cleaner is specifically designed to loosen and bond damaging scale and debris, allowing it to be easily flushed from the system.

MC3+ starts to work as quickly as one hour after application. For maximum flexibility, it can be left in the system for up to 28 days.

- Residential sizes treat 33 gallons = up to 25% more than most leading brands
- 1 gallon jug treats 350 gallons / 2 gallon jug treats 750 gallons
- Contains inhibitors that provide a protective coating for vulnerable metals during cleaning
- Compatible with all metals including aluminum
- Can be left in the system for 28 days for extra job flexibility during busy heating season
- Formulated using compensation chemistry meaning MC1+ inhibitor will compensate for up to 20% of MC3+ cleaner residues remaining in a system after draining
- The MC3+ bottle can be dosed into the system through the MagnaClean filter
- MC3+ Rapide can be injected into the system via any available boiler drain and can be completed in as little as 20 seconds
- Restores heating efficiency
- Non-foaming - does not cause any waterway issues or blockages
- In-house laboratory formulation of chemicals - no 3rd parties
- Quality assurance through rigorous in-house testing
- Environmentally friendly - biodegradable
- High concentrate formula
- Helps reduce heating and maintenance bills



Product codes:

Residential
MC3+ Cleaner: CH1-03-01670-US
MC3+ Rapide: CH1-03-01645-US

Commercial
MC3+ 1.1-gal Container: CH1-03-01725
MC3+ 2.2-gal Container: CH1-03-01726



Clean

MC5™

Hydronic RapidFlush SYSTEM CLEANER

High performing MC5™ RapidFlush System Cleaner is an advanced strength system cleaner designed to work with ADEY's MagnaCleanse® flushing unit, effectively removing heating system sludge, debris and scale while delivering exceptional cleansing results within 7 days.

- Time left in system: min = 1 hour / max = 7 days, making it ideal for full cleanse with MagnaCleanse
- Safe to use for systems with all metals, including aluminum
- Use heat if possible – As an approximate guideline, every 10°C / 18°F doubles the chemical reaction time of the cleaner
- In-house laboratory formulation of chemicals - no 3rd parties involved
- Quality assurance through rigorous in-house testing
- Environmentally friendly – biodegradable and recyclable
- 500ml bottle treats 26 gallons

Product codes:

CH1-03-00999-US

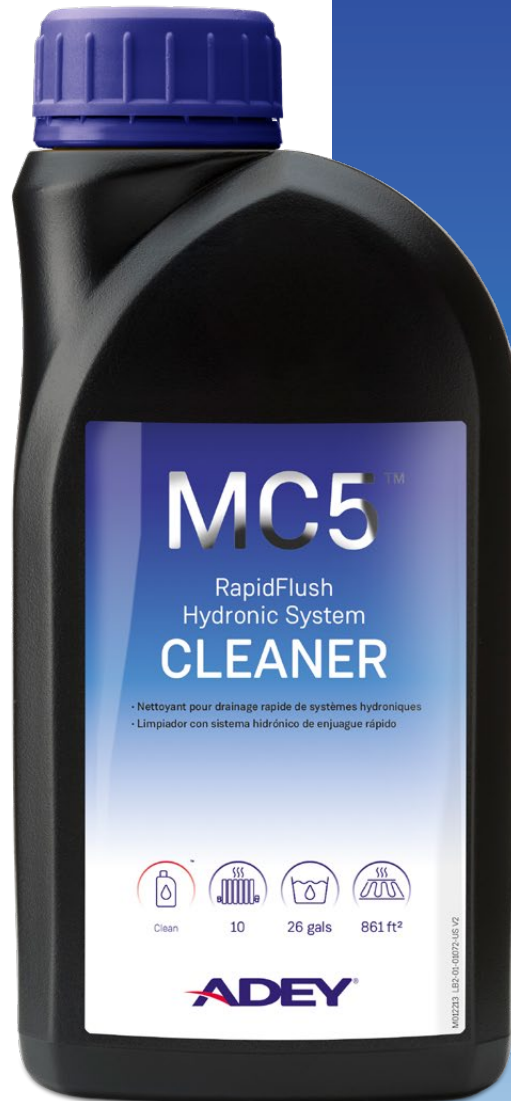

Clean

MC40+™

Hydronic System CLEANER & DE-SCALER

High strength *MC40+™* is a powdered chemical cleaner specially designed to remove calcium and limescale deposition, and heavy sludge deposits within 4 hours. Rapid-performing and fast-acting, the *MC40+* delivers an advanced clean with a highly concentrated formula, treating 33 gallons.

- Removes heavy scale, calcium, and sludge deposits
- High performing, fast-acting chemical cleaner
- Clean in as little as 1 hour, max 4 hours
- Neutralizer packets included
- High concentrated formula treats 33 gallons
- In-house laboratory formulation of chemicals - no 3rd parties
- Quality assurance through rigorous in-house testing
- Environmentally friendly - biodegradable and recyclable
- Free-flowing power makes it ideal for use with MagnaCleanse
- Restores heating efficiency
- Helps reduce heating and maintenance bills
- Suitable for all hydronic heating systems



Product codes:

CH1-03-03420-US



Clean

MC1+[®]

MC1+[®] *Rapide*

Hydronic Heating System PROTECTOR

Corrosion and scale can block narrow boiler waterways and high performance circulators. MC1+[®] prevents scale build-up and slows harmful oxidation that causes the formation of black sludge, while neutralizing pH levels to prevent future corrosion and scale build-up.

- Residential sizes treat 33 gallons = up to 25% more than most leading brands
- 1 gallon jug treats 350 gallons / 2 gallon jug treats 750 gallons
- Most pH buffered product on the market to prevent future corrosion
- Best-in-class formulation for mild steel protection to prevent magnetite generation
- Every batch of MC1+ is QC and performance tested
- Compatible with all metals, including aluminum
- Formulated using compensation chemistry. MC1+ inhibitor will compensate for up to 20% of MC3+ cleaner residues remaining in a system after draining
- The MC1+ Protector can be dosed into the system through the *MagnaClean* filter
- MC1+ Rapide can be injected into the system via any available boiler drain and can be completed in as little as 20 seconds
- In-house laboratory formulation of chemicals - no 3rd parties
- Quality assurance through rigorous in-house testing
- Environmentally friendly - biodegradable
- Maintains heating efficiency
- Helps reduce heating costs and maintenance bills



Product codes:

Residential

MC1+ Protector: CH1-03-01669-US

MC1+ Rapide: CH1-03-01640-US

Commercial

MC1+ 1.1-gal Container: CH1-03-01723

MC1+ 2.2-gal Container: CH1-03-01724



Protect



Water testing

Testing the quality of hydronic system water is the first and foremost step of counteracting corrosion in any hydronic systems.

It is essential to understand what contaminants are in the system water, including new system water. New system water may look clear, but doesn't necessarily mean that it is.

ADEY's corrosion, pH and inhibitor* quick test strips provide an on-site opportunity to assess, diagnose, and restore or treat any new or existing system water.

Benefits

- Rapid on-site analysis of critical water quality issues
- Immediate results on-site - no waiting around for 3rd party results
- Fewer call-backs following the testing and maintenance of total critical parameters

*Inhibitor tests for any molybdate based inhibitor

MagnaClean RapidTest™

Test for iron oxide a.k.a magnetite in 10 seconds!

Black iron oxide is a result of oxidation inside untreated hydronic systems, and can lead to components fouling and even failing.

Instructions:

1. Take a small sample of system water (in a bucket for example)
2. Dip and swirl the stick in the water sample for roughly 10 seconds
3. Remove and check for any magnetic particles stuck to the magnet
4. If magnetic particles are present, we strongly advise the use of ADEY's MC3+ cleaner, a MagnaClean filter, and MC1+ protector.

Ask your local Rep for a stick. Local Rep can be found here: www.adey.com/us/how-to-buy



Maintain

Maintaining is ADEY's fourth and final best practice step to counteracting corrosion. It prolongs system life and efficiencies, while growing the servicing side of your business at the same time.

Annual servicing and water testing promotes continual system protection.

Water quality should be tested annually with ADEY's *MC1+* inhibitor, pH and corrosion quick test strips, and *MagnaClean RapidTest* stick, and if required, the water should be topped up with ADEY's *MC1+* protector. More information on our water quality quick-test strips can be found on page 45, and our *MC1+* protector can be found on page 43.

ADEY's *MagnaClean* filter should be serviced annually. Although our filters do not restrict flow, there is only so much magnetite a magnetic filter will capture until it can capture no more. The last thing we want is a filter not being serviced, and on-going magnetite to circulate through vulnerable system components.

This annual service might open up the opportunity to fully cleanse the system with the *MagnaCleanse* unit too, especially if it's a system that hasn't been cleansed or flushed before.

More information on our *MagnaCleanse* flushing unit can be found on page 19.

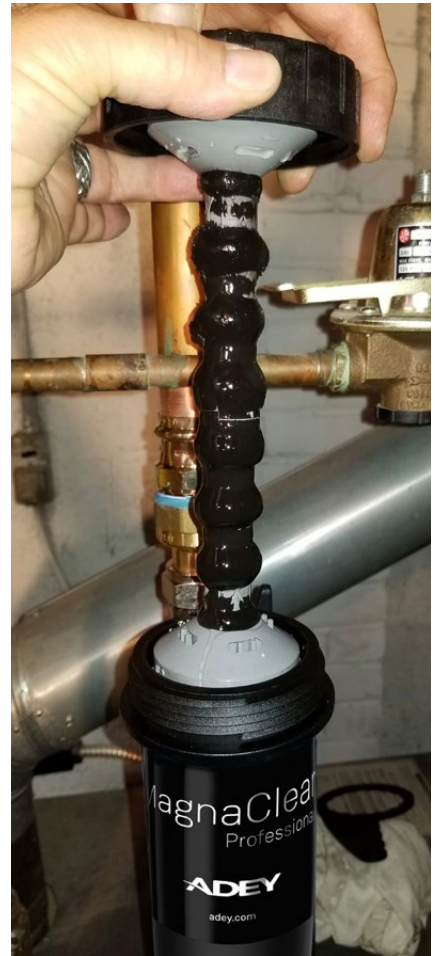

Top Tip
Check to see if a filter is installed and even if you didn't install it, service it anyway.

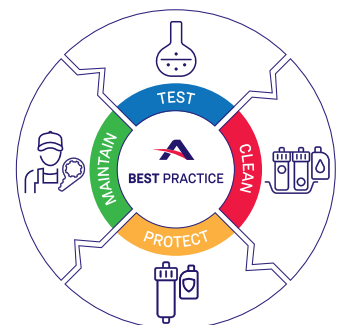

Resources

Find our latest news, case studies, training videos and events online at adey.com/us

Visit our Facebook, Twitter and LinkedIn pages to keep up to date with our latest information and product news.

ADEY Innovation LLC distributes throughout the USA and Canada. For your nearest rep, call the ADEY sales team or visit adey.com/how-to-buy



FREE *MagnaClean RapidTest*®!
Test for magnetite via 3 quick and easy steps with a *MagnaClean RapidTest*!

FREE when you sign up to up our newsletter!
Scan code or visit: www.adey.com/us/newsletter-sign-up

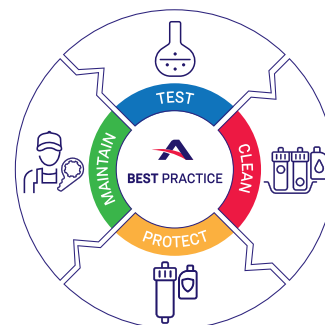



For more information on ADEY products, please call our
Customer Service team

Phone: +1 412 406 8292

Email: info@adeyusa.com

adey.com/us