



**MagnaClean Professional2XP®
In-line Magnetic Filter**

MagnaClean Professional2XP 1 ¼" NPT

SUBMITTAL DATA *MagnaClean Professional2XP* – ISSUE DATE 06/2022

Job name	Size
Job location	Quantity
Engineer	Approval
Mechanical contractor	Service
Contractor's P.O. No.	Tag No.
Representative	Notes

Application

In closed loop hydronic heating and chiller systems, the circulation of water contaminants such as copper, chloride, iron, scale, and pH imbalances may result in rapid corrosion, damage, and blockages to components such as ECMs, control valves, thermostats, heat exchangers, heat emitters and pipes, resulting in lower thermal efficiency within the system and even component failures. The *MagnaClean Professional2XP* filter provides residential system protection using rare-earth neodymium magnets that sit directly in the flow of water, on the return before the boiler, to capture damaging magnetic and non-magnetic debris before they enter the most expensive system component – the heat exchanger.

Delivering market leading dual-filtration performance, direct chemical dosing capability, and improved system efficiencies, the *MagnaClean Professional2XP* is an integral part of system maintenance and protection. System maintenance, the use of water treatment and filtration methods are often a requirement of the boiler manufacturer. See their manual and warranty.

Typical Specification

Furnish and install on the plans and described herein, an ADEY® *MagnaClean Professional2XP* magnetic filter as manufactured by ADEY. Each filter must be designed with a glass reinforced nylon body with large internal volume, seals in EPDM, blowdown drain port, air vent, a plastic sleeve over the magnet designed for easy servicing with two non-magnetic debris capture zones, and an internal powerful, neodymium magnet to capture particles from 50µm to 5µm (0.2 mil), including magnetite.

Each magnetic filter shall be an ADEY *MagnaClean Professional2XP* model or approved equal. (See product instructions for specific installation information.)

Dimensions

MagnaClean Professional2XP

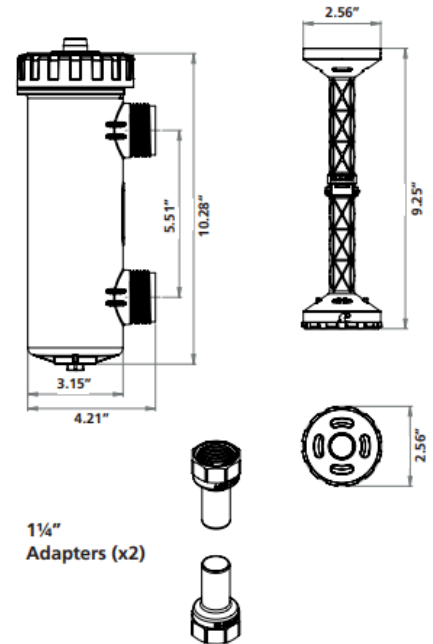

Pressure Drop Data

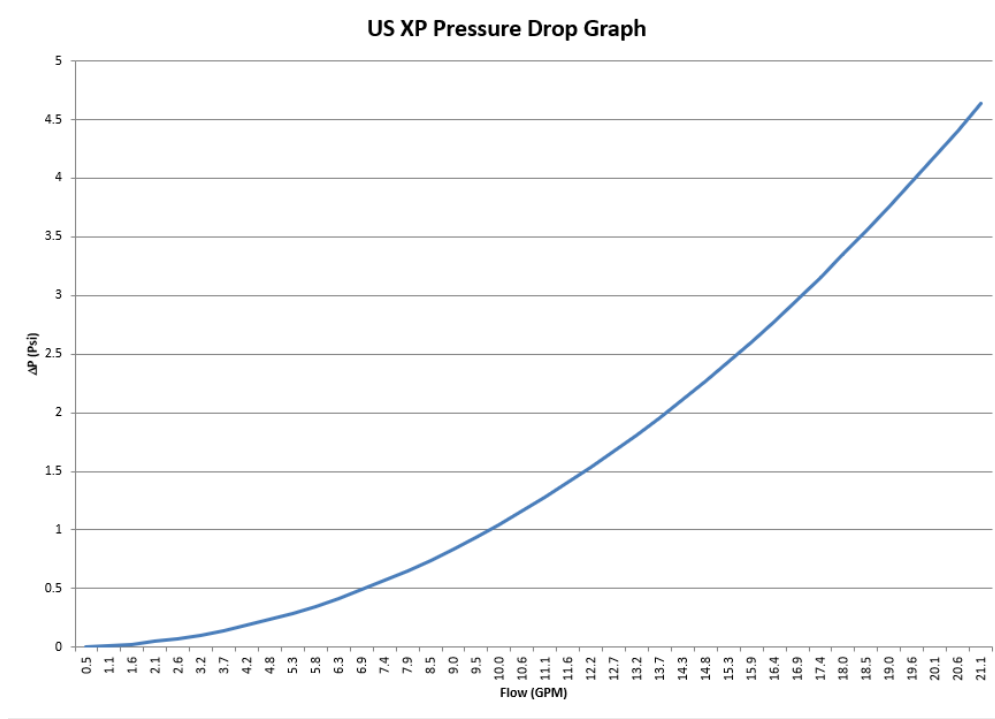

Technical Data

Canister:

Filter body & lid: Glass reinforced nylon

Fluid capacity: 0.22 gal / 0.84 litres

Inlet diameter: 1" at valve

Outlet diameter: 1" at valve

Thread: Pressure thread

Flow configuration: Bi-directional

Main lid seal: EPDM

Valve to canister: EPDM

Magnet Housing: Stainless steel

Length: 8 7/8"

Diameter: 3/4"

Bleed Valve material: Nickel plated brass

Seals: EPDM

Drain port plug material: Nickel plated brass

Drain plug thread: M8

Seals: EPDM

Triple seal valves:

Body material: Nickel plated brass

Seals material: Long life PTFE ball seals

O ring material: EPDM 70 seals x3

Valve inlet/outlet: 1 1/8"

Servicing clearance

Air vent (top): 2"

Drain Plug (bottom): 2"

Performance

Suitable fluids: water, glycol solution

Max. percentage of glycol: 50%

Max. working pressure: 87 psi (6 bar)

Max. working temperature: 203°F (95°C)

Particle separation capacity: down to 5 μm (0.2 mil)

Flow rate: 21 g/pm

Weight: 7.4 lbs

Connections - main: 1" compression, 1 1/4" NPT F